



Sensors for plastic manufacturing
Solutions in partnership from a single source

Sensor Solutions
Motion Control
Vision Technologies

Material supply

- Continuous granule supply
- Detection and positioning of semi-finished goods

Processing

- Clamping force monitoring
- Form fit
- Injection pressure monitoring
- Quality monitoring in the die
- Die monitoring

Control and handling

- Product and quality control
- Position monitoring
- Presence checking



Level control (hopper)

The level in the hopper is monitored by ultrasonic sensors regardless of the color and grain size.

Control of semi-finished goods supplies

Accurate, precise and reliable detection of parts regardless of their color with miniature optical sensors.

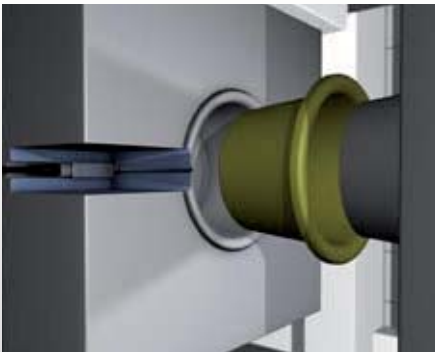

Cavity pressure, mold protection

Quartz sensors for direct and indirect injection pressure measurement detect pressures at high temperatures without difficulty.

Inductive sensors integrated in the mold monitor the closing position of the mold halves.

Force monitoring

Surface strain sensors and load cells measure low to high forces in the most diverse applications. They are excellently suited to constant force and quality monitoring.



Web tear monitoring for films

Web tear monitoring insensitive to dirt and dust with ultrasonic through beam sensors. Detection of thin and transparent films and strips.

Handling and robotics

Monitoring of rotary movements in diverse applications with Baumer encoders in conveying equipment and robotics.

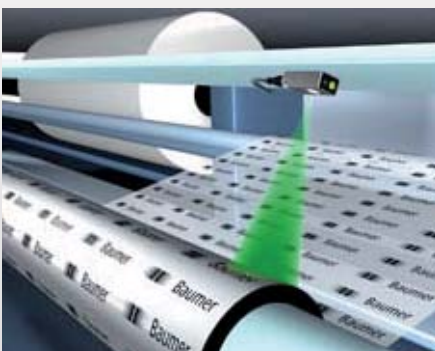

Measurement of roll diameters

Measuring ultrasonic sensors reliably monitor the winding and unwinding of the most diverse materials.

Detection of miniature parts

Laser sensors detect the smallest parts quickly and accurately regardless of the color or material.

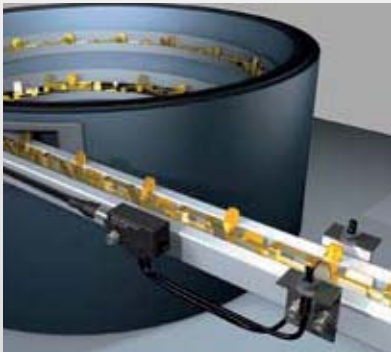

Robot applications

Detection and positioning of semi-finished products with analog ultrasonic sensors or vision sensors.

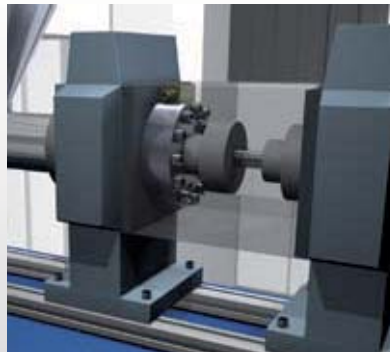

Injection pressure/clamping force

Load cells monitor large injection forces with high precision. Strain rings and probes measure these forces in the form of strain on and in the tie bar. Strain clamps are used for calibration to determine parallelism, closing force and bending.

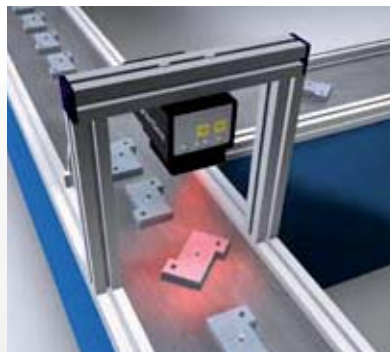

Monitoring of semi-finished products and injection molded parts

Vision sensors inspect injection molded parts before and after processing to verify their completeness, shape and position.



Measuring distances

Sensors measure distances regardless of color with a resolution of up to 2 μm . Steps or reference surfaces of injection molded parts can be accurately measured in this way.

Applications in plastic processing

Our pre-conditions to fulfill your requirements are

- Partnership, competence, dynamic
- The right sensor for each procedure
- Single source
- Open for your challenges

The right product for every process

- **Material supply**
 - Fiber-optic sensors
 - Ultrasonic sensors
 - Photoelectric sensors
- **Processing**
 - Photoelectric sensors
 - Strain sensors
 - Piezo-electric sensors
 - Inductive sensors
 - Force sensors
- **Control and handling**
 - Vision sensors
 - Encoders
 - Ultrasonic sensors
 - Photoelectric sensors
 - Inductive sensors



The competent partner for the plastics industry

Baumer supplies sensors to the plastic processing industry for use on equipment throughout the different stages of production. Our diverse range of sensors can be utilised in various applications from the supply of the raw materials, the control of the piece parts throughout the process, pressure monitoring within the mold, the subsequent handling and control right up to the monitoring of shrink-wrapping.

You will find the perfect solution from a single source.

Baumer sensor competence also includes...

Sensor Solutions

- Photoelectric sensors
- Inductive sensors
- Capacitive sensors
- Ultrasonic sensors
- Magnetic sensors
- Force and strain sensors
- Precision switches
- Fiber-optics and fiber-optic sensors
- Vision sensors
- Color sensors
- OEM custom developments



Motion Control

- Encoders
- Counters
- Process displays
- Spindle positioning systems
- Actuators and positioning drives
- Resolvers
- Speed switches
- Tachogenerators
- Angle measuring systems



Vision Technologies

- Digital cameras
- Intelligent cameras
- Smart vision sensors
- OEM camera modules
- Optical inspection systems
- Surface inspection
- Parts inspection
- OCR- and code identification



Process Instrumentation

- Pressure measurement
- Temperature measurement
- Level measurement
- Process analysis



Further details can be found at – www.baumergroup.com

Baumer

Baumer Switzerland

Baumer Electric AG · P.O. Box
Hummelstrasse 17 · CH-8501 Frauenfeld
Phone +41 (0)52 728 1122
Fax +41 (0)52 728 1144
sales.ch@baumerelectric.com
www.baumerelectric.com

Baumer United Kingdom

Baumer Ltd. · 33/36 Shrivenham Hundred Business Park
Watchfield · Swindon SN6 8TZ GB
Phone +44 (0)870 161 3000
Fax +44 (0)870 161 3030
sales.uk@baumergroup.com
www.baumergroup.com

Baumer USA

Baumer Ltd. · 122 Spring Street, Unit C-6
US-Southington, CT 06489
Phone +1 (1)860 621-2121
Fax +1 (1)860 628-6280
sales.us@baumergroup.com
www.baumerelectric.com