

ExEIL580P-SC

Solid shaft with clamping flange

每圈1至65536个脉冲·可编程（插值系统）

产品一览

- 尺寸 \varnothing 58 mm
- Precise optical sensing (interpolated)
- 输出信号电平可编程 (TTL 或 HTL)
- Clamping flange
- 轴向·径向或切向连接
- 每圈1...65536个脉冲,可编程
- 极强的抗冲击和抗振动性
- Option 0122, Explosion protection zone 22



技术数据

技术数据 – 电气参数

电源电压	4.75...30 VDC
反极性保护	是
短路保护	是
电流消耗 (无负载)	≤ 70 mA
初始化时间	≤ 30 ms (上电后)
每圈脉冲数	1 ... 65536
占空比	45...55 % (分辨率为1024和2048ppr时的典型值·详情参见占空比表格)
参考信号	零脉冲· 90° 或 180°
感应原理	光电
输出频率	≤ 300 kHz (TTL) ≤ 160 kHz (HTL)
输出信号	A+ · B+ · R+ · A- · B- · R-
输出方式	TTL/RS422 HTL/推挽式
可设置参数	输出电平TTL/HTL 脉冲数: 1...65536 零脉冲宽度: $90^\circ/180^\circ$ 零脉冲位置 信号序列
抗干扰性	EN 61000-6-2
辐射干扰	EN 61000-6-3

技术数据 – 机械参数

尺寸 (法兰)	$\varnothing 58$ mm
---------	---------------------

技术数据 – 机械参数

轴类型	$\varnothing 10 \times 20$ mm · 实心轴带紧固面
允许轴负载	≤ 40 N 轴向 ≤ 80 N 径向
法兰	夹紧法兰
防护等级 (EN 60529)	IP 65
运行速度	≤ 12000 rpm (+20 °C) ≤ 11000 rpm (+40 °C) ≤ 8000 rpm (+60 °C)
启动转矩	$\leq 0,015$ Nm (+20 °C)
材质	外壳: 压铸铝 法兰: 铝 实心轴: 不锈钢
环境温度	-20...+60 °C
相对湿度	90% (不结露)
耐抗性	EN 60068-2-6 抗振动30 g · 10-2000 Hz EN 60068-2-27 抗冲击300 g · 6 ms
防爆认证	II 3 D Ex tc III C T135°C Dc X (粉尘): 特殊条件 "X"
连接	M12 法兰接头 · 8针 M23 法兰接头 · 12针 电缆
近似重量	300 g

ExEIL580P-SC

Solid shaft with clamping flange

每圈1至65536个脉冲·可编程（插值系统）

端子定义

Flange connector M23, 12-pin / cable

Pin	Core color	Assignment
1	pink	B-
2	—	—
3	blue	R+
4	red	R-
5	green	A+
6	yellow	A-
7	—	R-Set ¹⁾
8	grey	B+
9	—	—
10	white	GND
11	—	—
12	brown	UB

Screen: Connected to housing

Cable data: PUR, [4x2x0,14 mm²], bending radius >45,8 mm, outer diameter 6.1 mm

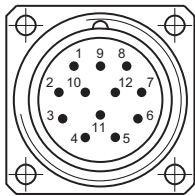

¹⁾ The R-Set input is used to set the reference pulse (zero pulse) on the current shaft position.
R-Set = UB ≥ 200 ms

Flange connector M12, 8-pin

Pin	Assignment
1	GND
2	UB
3	A+
4	A-
5	B+
6	B-
7	R+
8	R-

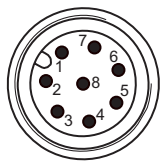

输出信号

Zero pulse electrical 90° A&B high
(Factory setting at clockwise rotation (CW)
in view of the encoder flange)

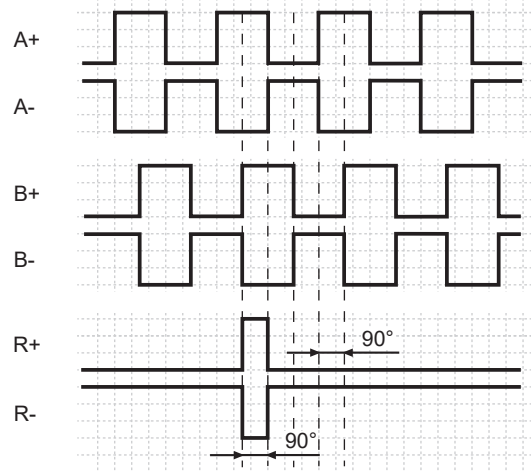

Zero pulse electrical 180° B low
(at clockwise rotation (CW)
in view of the encoder flange)

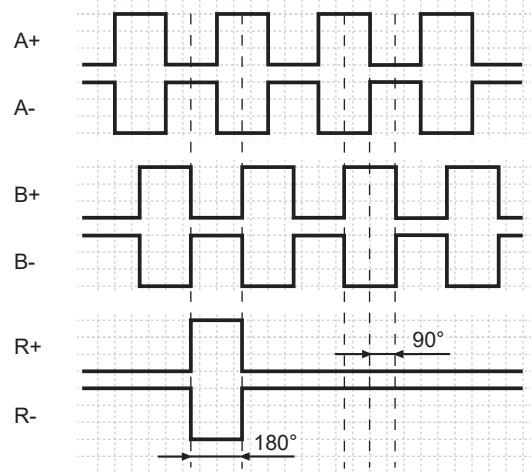

触发电平

Outputs	TTL/RS422
Output level High	≥2.5 V
Output level Low	≤0.5 V
Load	≤20 mA

Outputs	HTL/Push-pull
Output level High	≥UB -3 V
Output level Low	≤1.5 V
Load	≤20 mA

占空比

The duty cycle (D) is defined as the time ratio between the HIGH pulse duration (H) and the pulse period (T).

System-induced and depending on the pulse number, the measured values may vary which has an impact on speed and position acquisition. Binary pulse numbers are recommended for speed feedback.

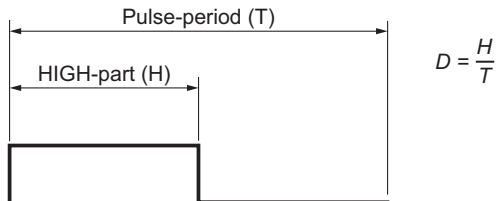

Programmed pulse number	Scan ratio (D) (maximum)	Jitter (+/-) (maximum)
1...1023	45...55 %	5%
1024, 2048	45...55 %	5%
1025...5000	40...60 %	10%
8192, 16384	35...85 %	15%
5001...10000	22...78 %	28%
32768	25...75 %	25%
65536	15...85 %	35%
all other	Jitter[%]=(programmed pulse number -10000)*0,0007%+28%	

防爆认证

⊕ II 3 D Ex tc IIIC T135°C Dc X (dust)

General- and Special conditions „X“:
Only put the device into operation if ...

- all necessary precautions have been taken by the operator to make sure device and connector are fully protected against mechanical impacts or shocks in compliance with EN 60079-0, section 26.4.2 (Special conditions „X“).
- the connection is mechanically or electrically secured to prevent any interrupt while the contact is live (Special conditions „X“).
- it has been ensured the electrical connection of product variants with cable outlet or cable couplings is outside zone 22 (Special conditions „X“).
- it has been ensured the maximum operating speed in relation to the ambient temperature is within the specifications on the table „Maximum rotation speed below“ (Special conditions „X“).
- the specifications on the product label match the on-site conditions for use in hazardous areas (EX) (device group, category, zone, temperature class resp. maximum surface temperature).
- the specifications on the product label comply with the prevailing grid conditions.
- the device shows no visible trace of damage (resulting from transport or storage), and
- it has been ensured no explosive atmosphere, oils, acids, gases, vapors, radiation etc. are present during installation.

Observe standard EN 60079-14 for installation and commissioning.

Device operation must observe the installation and operating instructions. The intended use and application of the device comes under the relevant legislation as well as applicable directives and standards.

Maximum rotation speed

	ambient temperature	rotation speed
solid shaft	20 °C	≤ 12000 rpm
	40 °C	≤ 11000 rpm
	60 °C	≤ 8000 rpm
through hollow shaft	20 °C	≤ 6000 rpm
	40 °C	≤ 4500 rpm
	60 °C	≤ 2500 rpm
blind hollow shaft	20 °C	≤ 8000 rpm
	40 °C	≤ 8000 rpm
	60 °C	≤ 5000 rpm

ExEIL580P-SC

Solid shaft with clamping flange

每圈1至65536个脉冲·可编程（插值系统）

尺寸

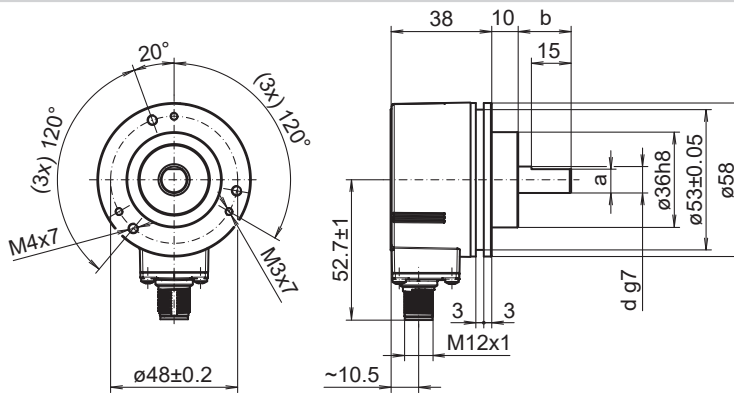

夹紧法兰·M12接头·径向

d g7	a	b
ø9.525	8.64	20.32
ø10	9.	20

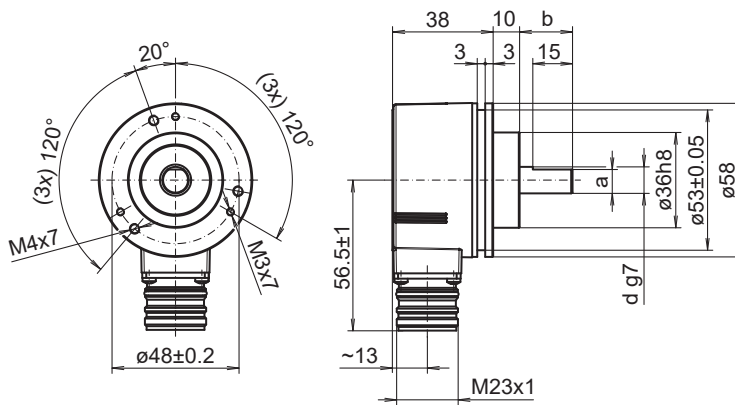

M23接头·径向

d g7	a	b
ø9.525	8.64	20.32
ø10	9.	20

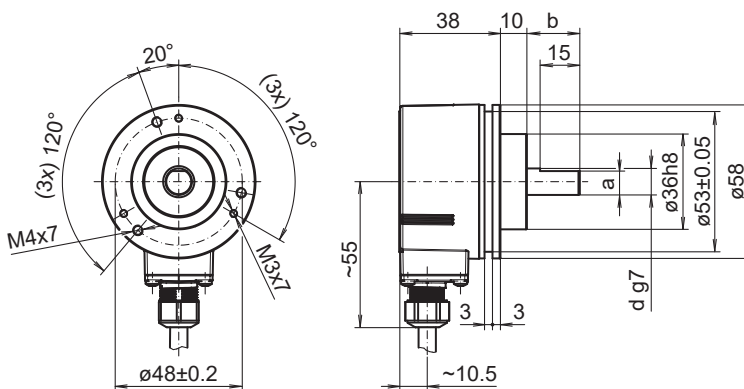

径向电缆出线

d g7	a	b
ø9.525	8.64	20.32
ø10	9.	20

ExEIL580P-SC

Solid shaft with clamping flange

每圈1至65536个脉冲·可编程（插值系统）

尺寸

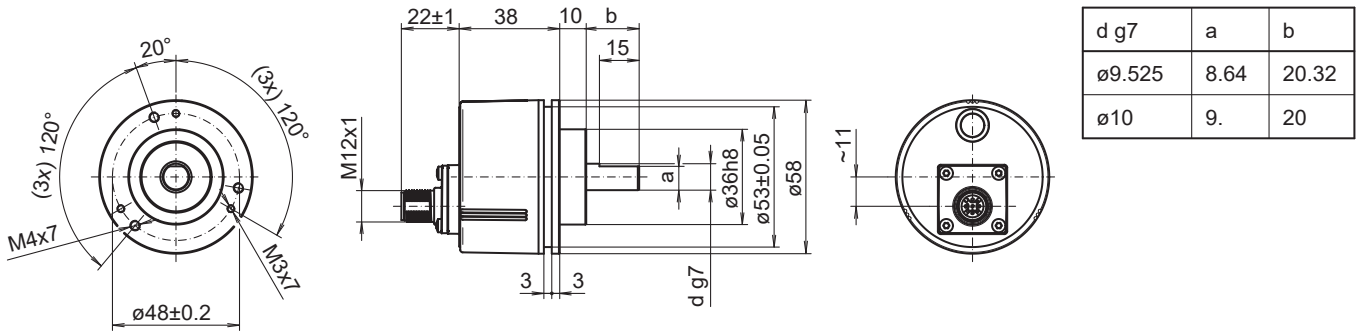

夹紧法兰·M12接头·轴向

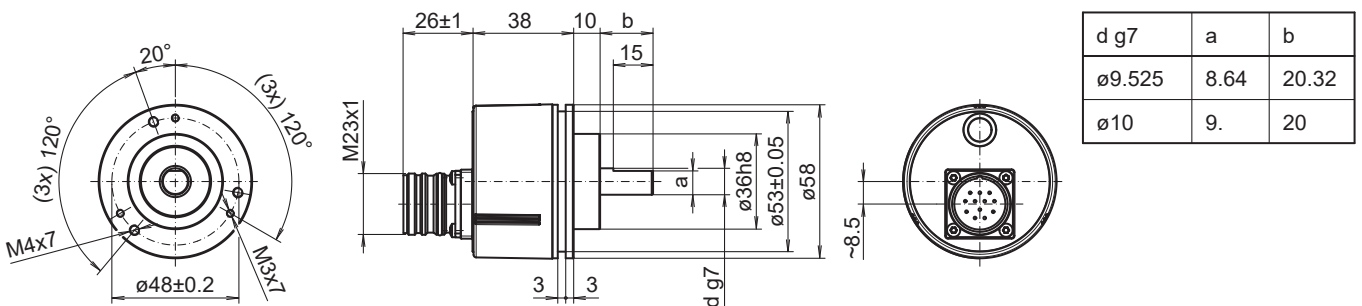

M23接头·径向

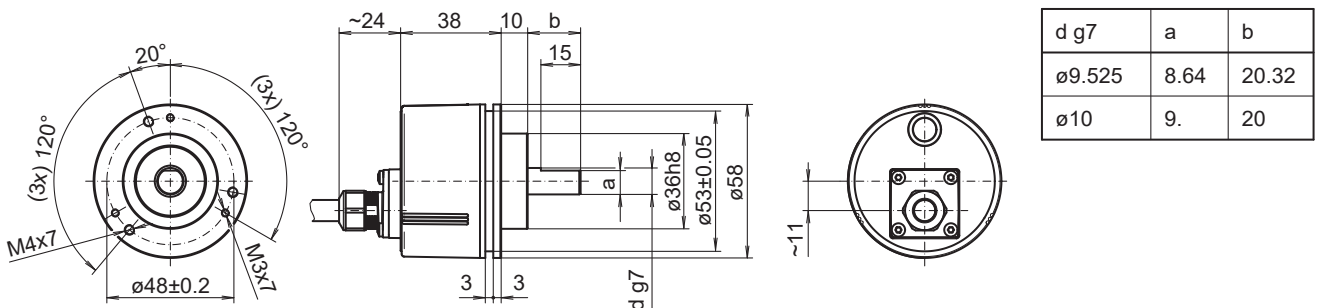

轴向电缆出线

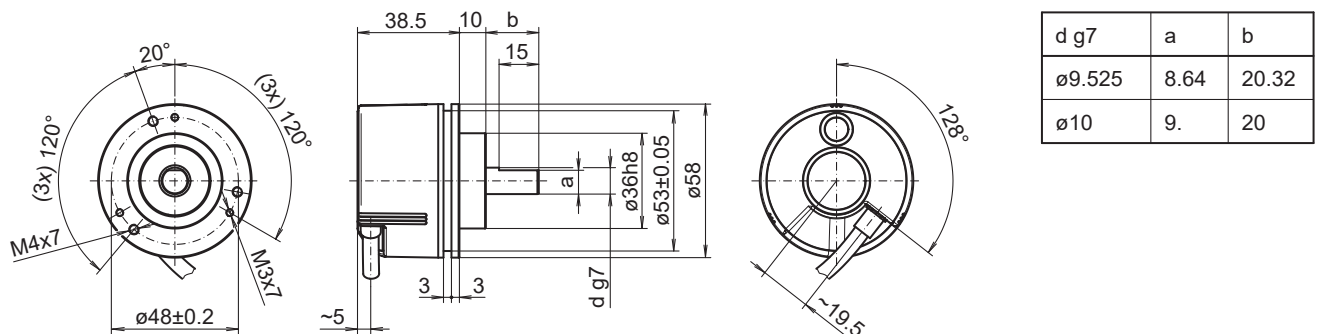

切向电缆出线

ExEIL580P-SC

Solid shaft with clamping flange

每圈1至65536个脉冲 · 可编程 (插值系统)

订货资料

	ExEIL580P	-	S	C	##	.	5	##	#	.	01024	.	F	/	0122
Product	ExEIL580P														
Shaft type	Solid shaft		S												
Flange (shaft)	Clamping flange, centering collar ø36 x 10 mm, pitch circle diameter 48 mm - 3xM3/3xM4			C											
Shaft	ø10 x 20 mm, with flat						10								
	ø3/8 x 4/5 (Ø9.525 x 20.32 mm), with flat						U3								
Protection class	IP 65							5							
Connection	Flange socket axial, M12, 8-pin, male contacts, CCW														A
	Flange socket radial, M12, 8-pin, male contacts, CCW														B
	Flange socket axial, M23, 12-pin, male contacts, CCW														D
	Flange socket radial, M23, 12-pin, male contacts, CCW														F
	Cable radial, 2 m														L
	Cable tangential, 1 m														P
	Cable tangential, 2 m														Q
	Cable radial, 1 m														R
	Cable axial, 1 m														T
	Cable axial, 2 m														U
Voltage supply / output	4,75...30 VDC, HTL/push pull, 6 channel (Vout=Vin)														Q
	4,75...30 VDC, TTL/RS422 6 channel (Vout=5V)														F
Pulses programmable	1...65536 可编程 (工厂默认设定:1024)											01024			
Operating temperature	-20...+60 °C														F
Optionen BT	ATEX Zone 22														

(出厂设置 : 1024 ppr · Vout = 5 VDC TTL · 信号序列A超前B (顺时针) · 零脉冲90° A和B高电平)

0122

ExEIL580P-SC

Solid shaft with clamping flange

每圈1至65536个脉冲·可编程（插值系统）

附件

安装附件

11065915	联轴器 CPS25 L=19 d1=04/d2=10
11065918	联轴器 CPS25 L=19 d1=07/d2=10
11065920	联轴器 CPS25 L=19 d1=08/d2=10
11065921	联轴器 CPS25 L=19 d1=09/d2=10
11065922	联轴器 CPS25 L=19 d1=10/d2=06
11065923	联轴器 CPS25 L=19 d1=10/d2=10
11065924	联轴器 CPS25 L=19 d1=10/d2=11
11065925	联轴器 CPS25 L=19 d1=10/d2=12
10141132	弹簧垫圈联轴器 D1=6 / D2=10 (Z 121.C01)
10141133	弹簧垫圈联轴器 D1=10 / D2=10 (Z 121.C03)
11034138	弹簧垫圈联轴器 D1=10 / D2=16 (Z 121.C04)
11034140	弹簧垫圈联轴器 D1=10 / D2=14 (Z 121.C06)
11034141	弹簧垫圈联轴器 D1=10 / D2=12 (Z 121.C07)
11050507	铝制/不锈钢波纹管联轴器 D1=06 / D2=10
11101781	双环联轴器 D1=10 / D2=10
10125051	夹紧法兰型编码器用安装适配器 (M3) (Z 119.017)
11065545	偏心紧固件组合 (A型)
11101893	编码器弹簧臂

编程附件

11120657	手持式编程工具Z-PA-EI-H
11120547	PC编程工具 Z-PA-EI-P
11119280	连接电缆·M12接头 / D-SUB接头·0.2m
11119720	连接电缆·M12接头 / D-SUB接头·1 m
11119257	连接电缆·M23接头(顺时针) / D-SUB接头·0.2m
11119723	连接电缆·M23接头(顺时针) / D-SUB接头·1 m