

# *HDmag flex*

Your encoder application all wrapped up.





## Convenient.

Unpack, mount and measure: Speed and position feedback at large shafts has never been easier. A single person can install the innovative magnetic belt encoder within minutes – even if the shafts are 3 meters in diameter. The magnetic belt adapts to the machine or generator shaft like a belt. Conveniently and safely secured with a lock, it will drastically cut down on your installation costs:

- The drive shaft remains fully mounted.
- No mechanical shaft adaptations required.
- System will be down only for the time of encoder installation.

Ordering the encoder is likewise easy:

Tell us your shaft diameter, the desired line count and resolution for position and speed signal and we will deliver lots with up to five individualized magnetic belt encoders in just 10 working days.

## Retrofits made easy.

The magnetic belt encoder is the easiest and fastest retrofit solution for measuring the speed at medium-sized to large shafts:

- Shaft remains fully mounted
- No free shaft end required
- Installation of the magnetic belt and sensing head at any axial shaft position
- A single person can carry out installation within minutes
- Minimized system downtime, enhanced production flow and low overall costs



The belt can be mounted on painted or unfinished surfaces by a single person.

# Flexible.

Just unpack and see for yourself! The magnetic belt is wound up tightly in the packaging and, for a 1000 mm shaft, it weighs only 400 grams. Together with the sensing head, the system weighs under 1.5 kg. The standard magnetic belt encoder is designed for shaft diameters of 300 to 3183 mm.

The wide magnetic belt allows for robust encoding: The shaft can move back and forth axially up to 10 mm with a constantly high signal quality.

The magnetic belt encoder provides all output signals regardless of the shaft diameter. This is real cutting-edge technology: The matching resolution for any shaft diameter.



Figure shown in actual size  
165 x 25 x 93 mm

## *HDmag flex* – Technology for harsh conditions.

*HDmag flex* magnetic belt encoders operate on the proven *HDmag* principle which is based on high-resolution magnetic sensing and real time signal processing. The sensing head provides two adjustable sensing elements which are aligned in the factory to match the required shaft diameter. The high-precision magnetic belt is simply buckled on the shaft.

- Wear-free measuring technology
- High protection as well as shock and vibration resistance due to fully encapsulated electronics
- Unaffected by dust, dirt, liquids and condensation
- Dual sensing for constantly high signal quality at large air gap tolerances: axial  $\pm 5$  mm, radial 1 to 3 mm
- Electrical interfaces: SSI, HTL, TTL, SinCos and combinations
- Direct output of position and speed
- Output resolution independent of shaft diameter



## Precise.

Sensor signal processing in realtime provides the final speed signal ready for use by the control or regulating device.

The magnetic belt encoder plays to its strength when installed in the rotor lock on wind turbines and will provide the exact position on a 1000 mm shaft with an accuracy of  $\pm 0.02^\circ$ .

The extremely high resolution will even capture speed of mere 0.003 rpm, which is equivalent to a single rotation in 6 hours.



## Reduced downtimes.

The integrated function monitoring system continuously checks the encoder functions, speeding up the troubleshooting process and reducing downtime. A multicolor LED on the sensing head indicates device activity. Further it is a primary assistance during setup by indicating any excessively large radial distance between sensor and magnetic belt. In addition, the LED shows the initial calibration progress.

Installed in no  
time at all.

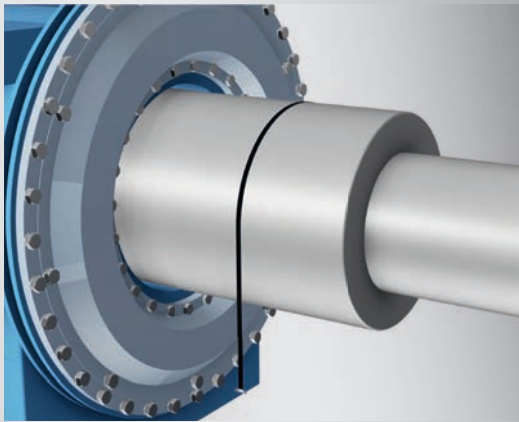

The adjustable magnetic strap is buckled like a belt on the drive or generator shaft and thus allows to work with even the largest diameters.

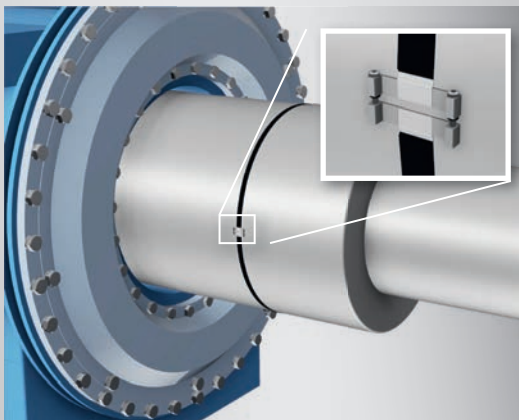

The lock is welded securely to the magnetic belt for maximum tractive force, holding the belt securely on the shaft.

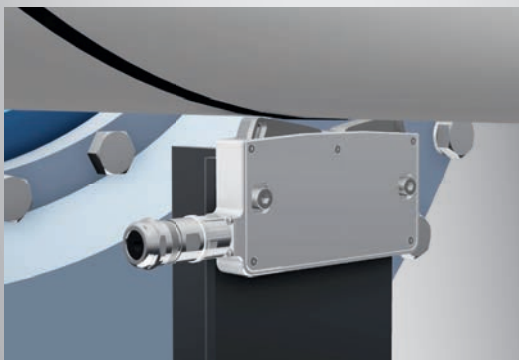

The sensing head allows for very high resolutions and large mechanical backlash.

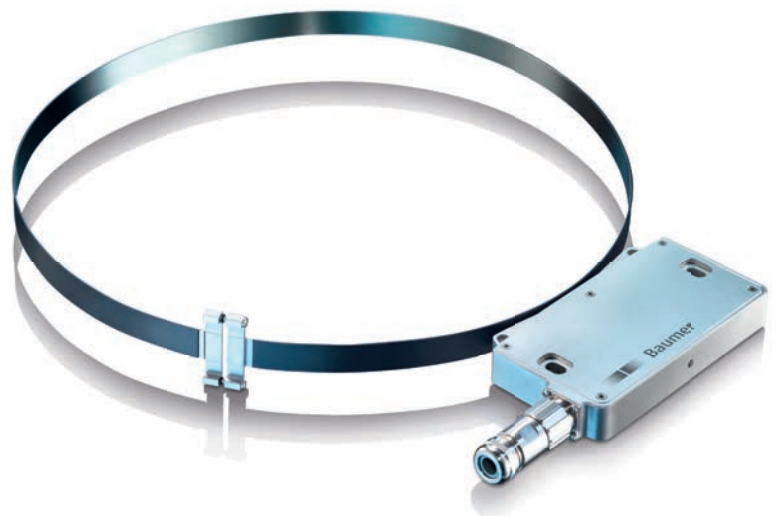

## Revolutionary.

Previous bearingless solutions with an encoder wheel quickly reached their mechanical design limitations with regard to cost and weight when used for large shaft diameters. Baumer provides an revolutionary approach with their innovative *HDmag flex* MIR 3000F and MQR 3000F bearingless magnetic belt encoders. Thanks to convenient mounting and unparalleled precision, these encoders prove themselves by extremely cost-effective technology for position and speed feedback at large shaft diameters:

- Maintenance free and bearingless non-contact magnetic sensing technology
- *HDmag flex* MIR 3000F (incremental):  
Line count up to 131 072 pulses per rotation, regardless of diameter
- *HDmag flex* MQR 3000F (quasi-absolute):  
Up to 20 bit resolution and up to 20 bit direct speed output, regardless of diameter
- Easy retrofit of existing systems

The magnetic belt encoder is designed for heavy-duty applications at large shafts:

- |  |                           |
|--|---------------------------|
| ■ Wind turbines                                    | ■ Generators              |
| ■ Hydroelectric plants                             | ■ Azimuth thrusters (POD) |
| ■ Large drive systems (roller mills, steel plants) | ■ Crane systems           |
|  | ■ Paper machines          |

# Product overview



	<i>HDmag flex MIR 3000 F</i>	<i>HDmag flex MQR 3000 F</i>
Function	Incremental	Quasi-absolute
Sensing method	Magnetic	
Voltage supply	4.75...30 VDC	
Output signals	HTL, TTL/RS422, SinCos 1 Vpp	SSI data (linedriver RS485)
Additional output signals	–	1024...4096 HTL, TTL/RS422, SinCos 1 Vpp
Shaft diameter	300...3183 mm	
Connection	M23 flange socket, 12-pin	M23 flange socket, 17-pin
Pulses per rotation	512...131072 (square wave pulses) 512...16384 (sinusoidal signals)	–
Resolution	–	Up to 20 bit singleturn
Speed resolution	–	Up to 20 bit
Operating temperature	–40...+85 °C	
Operating speed	Up to 1850 rpm, depending on shaft diameter	
Protection, sensing head	IP 67	
Resistance	IEC 60068-2-6 vibration 30 g, 10-2000 Hz IEC 60068-2-27 shock 300 g, 6 ms	
Option	Corrosion protection for offshore applications	



Learn more at:  
[www.baumer.com/hdmagflex](http://www.baumer.com/hdmagflex)

Find your local partner: [www.baumer.com/worldwide](http://www.baumer.com/worldwide)

 **Baumer**  
 Passion for Sensors

Baumer Group  
 International Sales  
 P.O. Box · Hummelstrasse 17 · CH-8501 Frauenfeld  
 Phone +41 52 728 1122 · Fax +41 52 728 1144  
[sales@baumer.com](mailto:sales@baumer.com) · [www.baumer.com](http://www.baumer.com)