

MHGE 800

 Magnetic sensing / Through hollow shaft max. \varnothing 740 mm
 512...32768 pulses or 512 sinewave cycles per turn

Overview

- Sinewave or square-wave signals
- Robust and wearless
- High protection through fully encapsulated electronics
- Large tolerances: axial \pm 3 mm, radial max. 2.2 mm
- Very compact dimensions
- Simple mounting, easy adaptation
- Magnetic rotor included in delivery

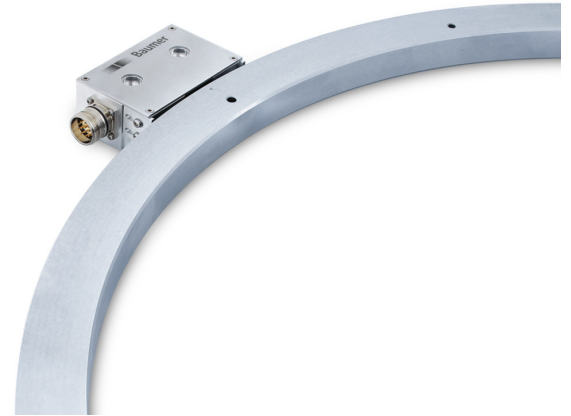

Technical data

Technical data - electrical ratings

Interference immunity	EN 61000-6-2
Emitted interference	EN 61000-6-3
Approval	CE UL approval / E217823 Option: DNV approval

Technical data - electrical ratings (square-wave)

Voltage supply	4.75...30 VDC
Consumption w/o load	\leq 70 mA
Pulses per revolution	512 ... 32768
Phase shift	$90^\circ \pm 10^\circ$
Duty cycle	40...60 %
Reference signal	Zero pulse, width 90°
Sensing method	Magnetic
Output frequency	\leq 300 kHz
Output signals	A+, B+, R+, A-, B-, R-
Output stages	HTL TTL/RS422

Technical data - electrical ratings (SinCos)

Voltage supply	5 VDC
Consumption w/o load	\leq 70 mA
Sinewave cycles per revolution	512
Phase shift	$90^\circ \pm 5^\circ$
Reference signal	Zero pulse, width 90°
Sensing method	Magnetic

Optional

- Redundant sensing head on request
- Increased operating speed through triple-bandage
- Offshore version (DNV approval) on request

Technical data - electrical ratings (SinCos)

Output signals	A+, B+, R+, A-, B-, R-
Output stages	SinCos 1 Vpp
Difference of SinCos amplitude	\leq 20 mV
Harmonics typ.	-40 dB
DC offset	\leq 20 mV

Technical data - mechanical design

Sensor head	Standard signal processing
Size (flange)	\varnothing 813 mm
Shaft type	\varnothing 650...740 mm (through hollow shaft)
Axial tolerance	\pm 3 mm (wheel/head)
Radial tolerance	0.1...2.2 mm (wheel/head)
Protection EN 60529	IP 67
Operating speed	\leq 1000 rpm
Material	Housing sensing head: aluminium alloy Wheel: stainless steel 1.4104 (option DNV: 1.4313)
Operating temperature	-40...+100 °C
Resistance	IEC 60068-2-6 Vibration 30 g, 55-2000 Hz IEC 60068-2-27 Shock 300 g, 2 ms
Accuracy of magnetic measure	$\pm 50''$
Connection	Flange connector M23, 12-pin Terminal box

MHGE 800

Magnetic sensing / Through hollow shaft max. $\varnothing 740$ mm
512...32768 pulses or 512 sinewave cycles per turn

Terminal assignment

View A (see dimension)
Assignment flange connector

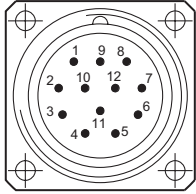

Flange connector M23,
male, 12-pin,
counter-clockwise (CCW)

Pin	Assignment
1	B-
2	dnu
3	R+
4	R-
5	A+
6	A-
7	dnu
8	B+
9	dnu
10	0V (\perp)
11	dnu
12	+UB

View B (see dimension)
Connecting terminal terminal box

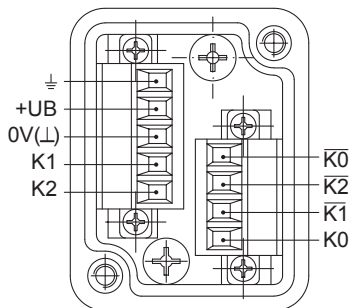

Terminal significance

+UB	Voltage supply
0V (\perp)	Ground
\perp	Earth ground (housing)
A+, K1	Output signal channel 1
A-, $\overline{K1}$	Output signal channel 1 inverted
B+, K2	Output signal channel 2 (offset by 90° to channel 1)
B-, $\overline{K2}$	Output signal channel 2 inverted
R+, K0	Zero pulse (reference signal)
R-, $\overline{K0}$	Zero pulse inverted
dnu	Do not use

Output signals

HTL/TTL

At positive rotating direction (see dimension)

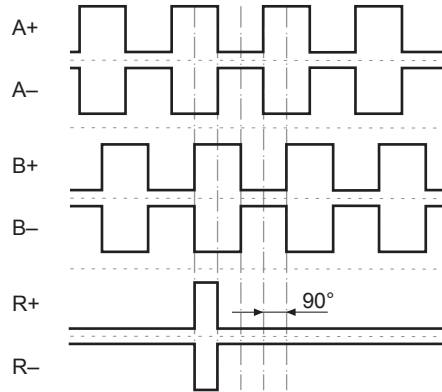

SinCos

At positive rotating direction (see dimension)

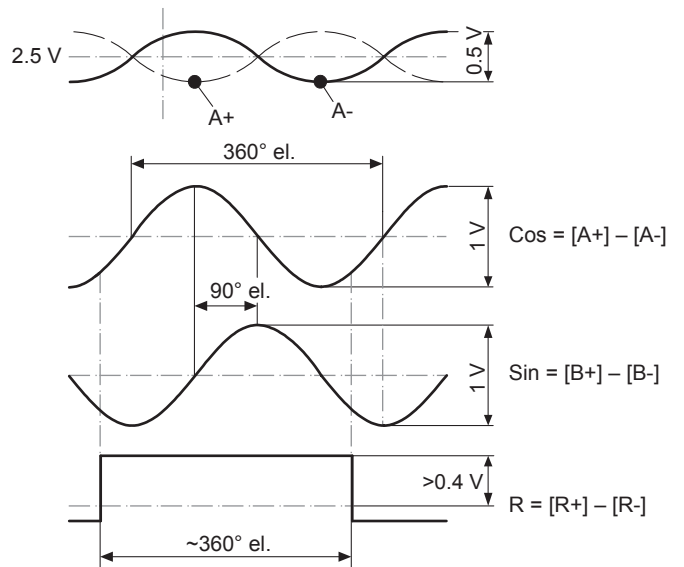

MHGE 800

Magnetic sensing / Through hollow shaft max. $\varnothing 740$ mm
512...32768 pulses or 512 sinewave cycles per turn

Dimensions

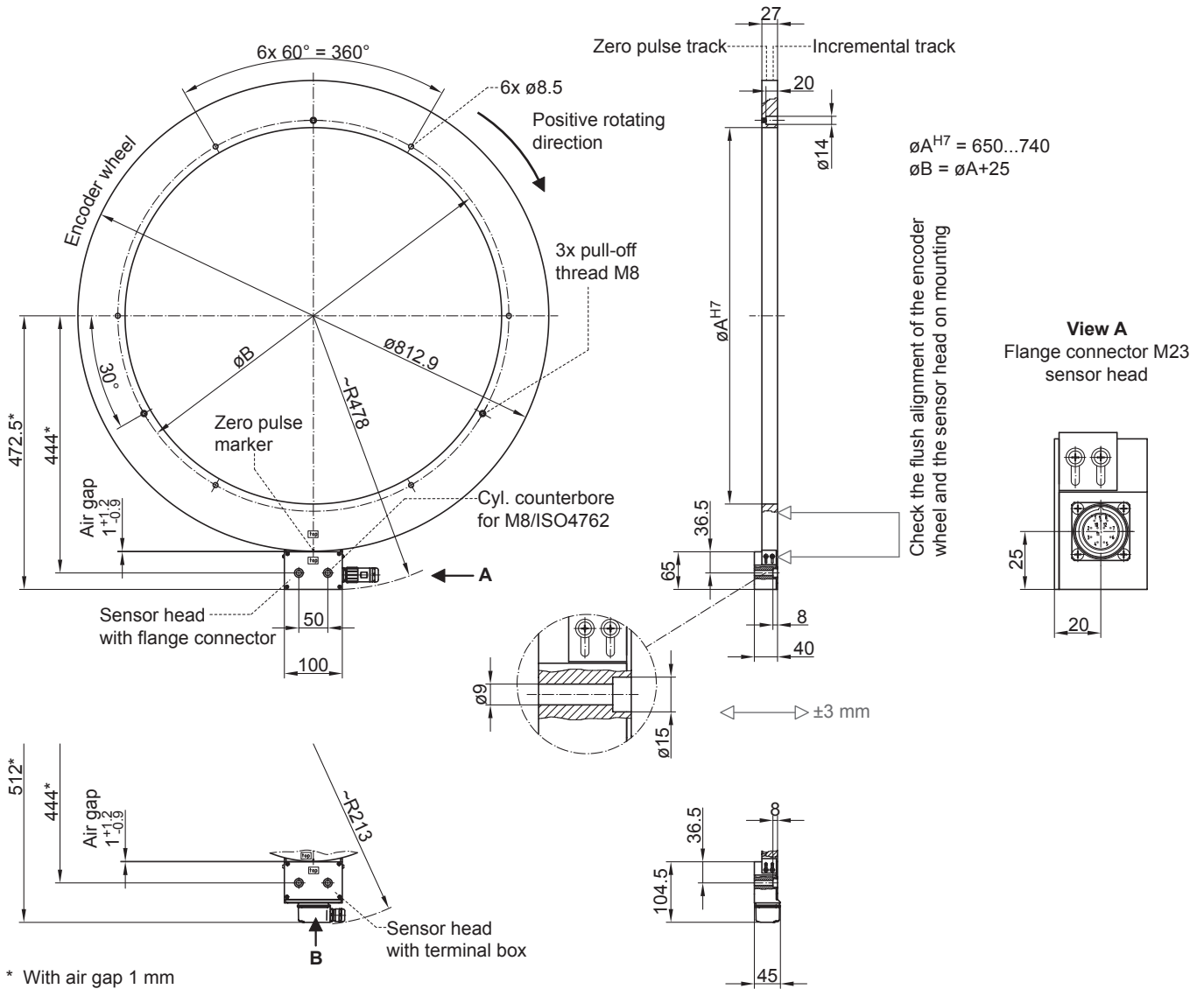

MHGE 800

 Magnetic sensing / Through hollow shaft max. \varnothing 740 mm
 512...32768 pulses or 512 sinewave cycles per turn

Ordering reference

	MHGE800	#	5	####	###	N	#####	#
Product	MHGE800							
Encoder without bearings - incremental	MHGE800							
Bandaging								
Encoder wheel standard bandage					B			
Encoder wheel with triple-bandage (optional)					T			
Pole width								
1 pole = 5 mm								5
Mounting type / hollow shaft (\varnothing mm)⁽¹⁾								
Screw mounting / \varnothing 650 mm								G650
Screw mounting / \varnothing 690 mm								G690
Screw mounting / \varnothing 700 mm								G700
Screw mounting / \varnothing 740 mm								G740
Voltage supply / output stage⁽¹⁾								
5 VDC / SinCos								S
4.75...30 VDC / TTL								R
5...30 VDC / 5 VDC = TTL, 10...30 VDC = HTL universal								U
Zero pulse								
With zero pulse								N
Pulse number/sinewave cycles⁽¹⁾								
512 (SinCos output)								512
4096								4096
8192								8192
16384								16384
32768								32768
Connection								
1x flange connector M23, tangential 12-pin, male, CCW								C
1x terminal box with cable gland M20, radial								B

(1) Other versions on request.