

Overview

- Leakage of parasitical shaft currents
- Blind hollow shaft $\varnothing 16 \dots 30$ mm

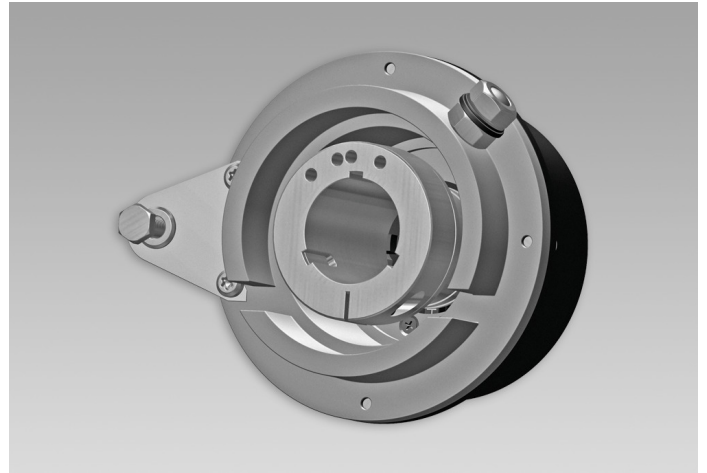

HUBNER
BERLIN
A Baumer Brand

Technical data

Technical data

Current load	≤ 1 A ≤ 12 A (short-term)
Operating speed	≤ 8500 rpm
Operating temperature	$-30 \dots +120$ °C
Admitted shaft load	≤ 150 N axial ≤ 200 N radial
Rotor moment of inertia	0.72 kgcm ² ($\varnothing 16$) 0.38 kgcm ² ($\varnothing 30$)
Operating torque	≤ 15 Ncm

Technical data

Protection EN 60529	IP 55
Weight approx.	1 kg
Shaft type	$\varnothing 16 \dots 30$ mm (through hollow shaft)
Material	Housing: aluminium
Resistance	IEC 60068-2-6 Vibration 10 g, 50-2000 Hz IEC 60068-2-27 Shock 100 g, 6 ms
Approval	CE

Description

The motor earthing unit is discharging parasitical shaft currents to avoid damage of the ball bearings.

Dimensions

