

POG 10

Solid shaft with EURO flange B10
300...5000 pulses per revolution

Overview

- TTL output driver for cable length up to 550 m
- High resistance to shock and vibrations
- EURO flange B10 / solid shaft $\varnothing 11$ mm
- Large terminal box, turn by 180°



Technical data

Technical data - electrical ratings

Voltage supply	9...30 VDC 5 VDC ± 5 %
Consumption w/o load	≤ 100 mA
Pulses per revolution	300 ... 5000
Phase shift	$90^\circ \pm 20^\circ$
Duty cycle	40...60 %
Reference signal	Zero pulse, width 90°
Sensing method	Optical
Output frequency	≤ 120 kHz ≤ 300 kHz (on request)
Output signals	K1, K2, K0 + inverted Error output (option EMS)
Output stages	HTL-P (power linedriver) TTL/RS422
Interference immunity	EN 61000-6-2
Emitted interference	EN 61000-6-3
Approval	CE UL approval / E217823

Technical data - mechanical design

Size (flange)	$\varnothing 115$ mm
Shaft type	$\varnothing 11$ mm solid shaft
Admitted shaft load	≤ 300 N axial ≤ 450 N radial

Technical data - mechanical design

Flange	EURO flange B10
Protection EN 60529	IP 66
Operating speed	≤ 12000 rpm (mechanical)
Operating torque typ.	2 Ncm
Rotor moment of inertia	212 gcm ²
Material	Housing: aluminium die-cast Shaft: stainless steel
Operating temperature	-40...+100 °C -25...+100 °C (>3072 pulses) -50...+100 °C (optional)
Resistance	IEC 60068-2-6 Vibration 20 g, 10-2000 Hz IEC 60068-2-27 Shock 200 g, 6 ms
Corrosion protection	IEC 60068-2-52 Salt mist for ambient conditions C4 according to ISO 12944-2
Explosion protection	II 3 G Ex nA IIC T4 Gc (gas) II 3 D Ex tc IIIC T135°C Dc (dust) (only with option ATEX)
Connection	Terminal box 2x terminal box (with option M)
Weight approx.	1.9 kg 2.1 kg (with option M)

Optional

- Function control with EMS
- Redundant sensing with two terminal boxes
- Second shaft end / Housing foot (B3)
- With heating up to -50°C

POG 10

Solid shaft with EURO flange B10
300...5000 pulses per revolution

Terminal assignment

View A (see dimension)

Connecting terminal box, radial

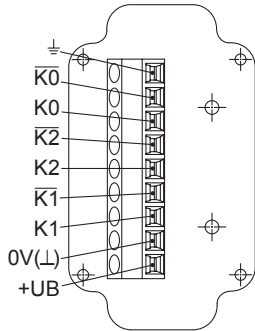

Option EMS: View A (see dimension)

Connecting terminal box, radial

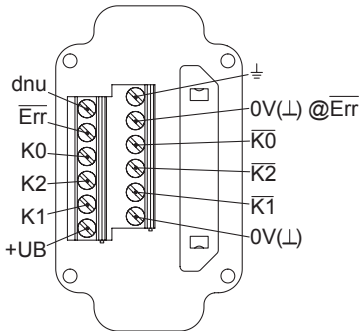

Terminal significance

+UB	Voltage supply
0V (L)	Ground
⊥	Earth ground (housing)
K1	Output signal channel 1
$\bar{K}1$	Output signal channel 1 inverted
K2	Output signal channel 2 (offset by 90° to channel 1)
$\bar{K}2$	Output signal channel 2 inverted
K0	Zero pulse (reference signal)
$\bar{K}0$	Zero pulse inverted
$\bar{E}rr$	Error output (option EMS)
dnu	Do not use

Output signals

HTL/TTL

At positive rotating direction (see dimension)

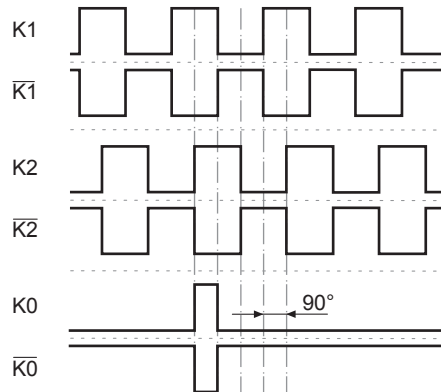

Option EMS: Status LED / error output

Flash light red*	Error of signal sequence, zero pulse or pulses (Error output = HIGH-LOW alternation)
Red	Overload output transistors (Error output = LOW)
Flash light green	Device o.k., rotating (Error output = HIGH)
Green	Device o.k., stopped (Error output = HIGH)
No light	No voltage supply connection or wrong connection (Error output = LOW)

* Only at rotating device

POG 10

Solid shaft with EURO flange B10

300...5000 pulses per revolution

Dimensions

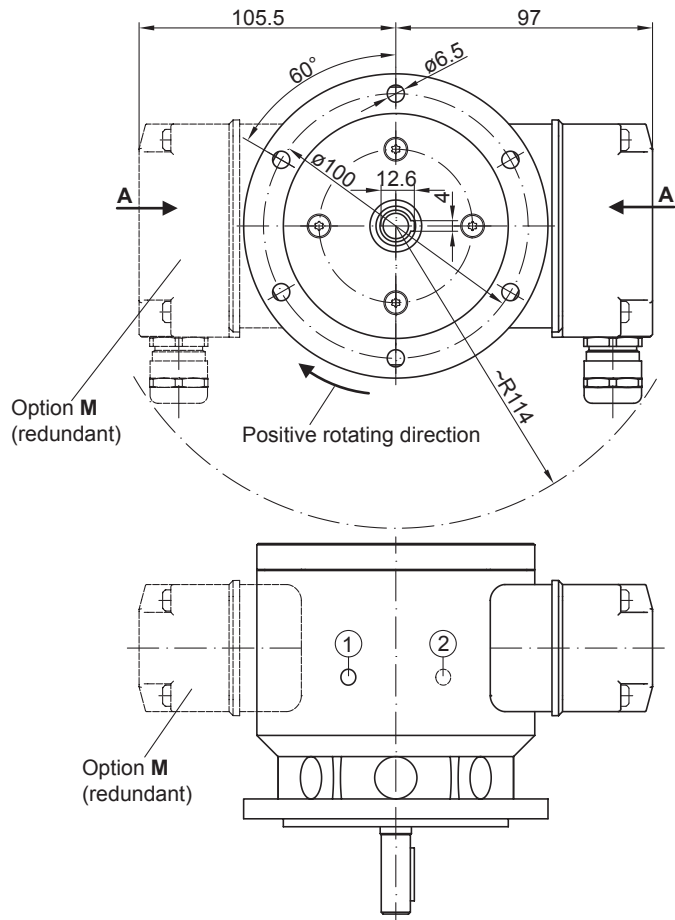
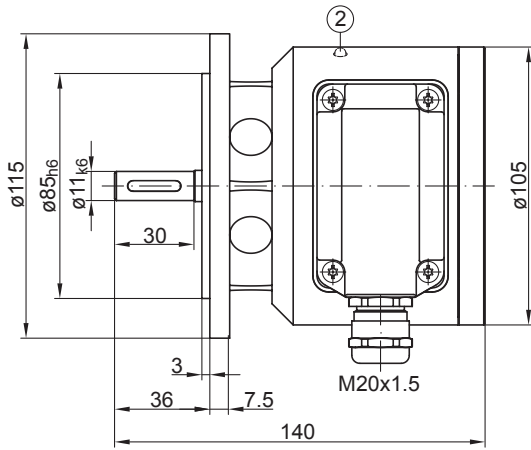

- ① Status LED (option EMS)
- ② Status LED (option **M** (redundant) and EMS)

EURO flange B10

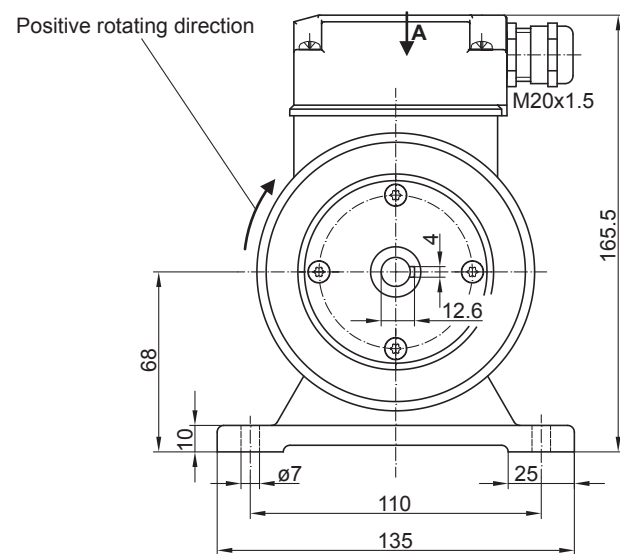
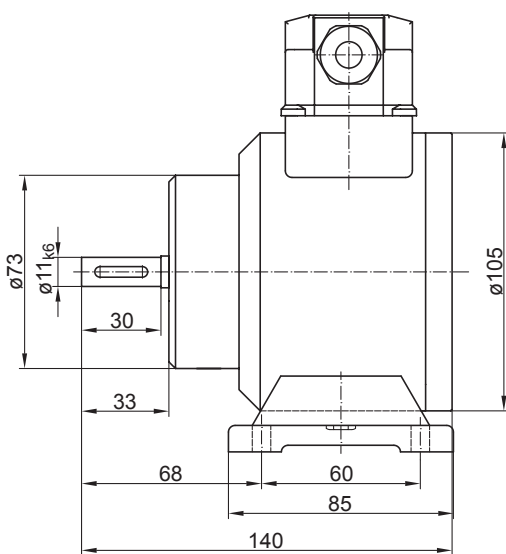

Housing foot B3

POG 10

Solid shaft with EURO flange B10

300...5000 pulses per revolution

Ordering reference

	POG10	##	#	DN	####	###	#####
Product	POG10						
Incremental encoder							
EMS - Enhanced Monitoring System							
Without EMS							
With EMS		.2					
Redundant sensing							
Without redundant sensing							
With redundant sensing			M				
Output signals							
K1, K2, K0				DN			
Pulse number⁽¹⁾							
300						300	
500						500	
512						512	
1000						1000	
1024						1024	
1200						1200	
2048						2048	
2500						2500	
3072						3072	
4096						4096	
5000						5000	
Voltage supply / output stage							
9...30 VDC / output stage HTL with inverted signals							I
5 VDC / output stage TTL with inverted signals							TTL
9...30 VDC / output stage TTL with inverted signals							R
Mounting type							
EURO flange B10							
Housing foot B3							B3

(1) Other pulse numbers on request.

Accessories

Mounting accessories

- Spring disk coupling K 35 (shaft ø6...12 mm)
- Spring disk coupling K 50 (shaft ø11...16 mm)
- Spring disk coupling K 60 (shaft ø11...22 mm)

Connectors and cables

- Sensor cable for encoders HEK 8

Diagnostic accessories

- 11075858 Analyzer for encoders HENQ 1100
- 11075880 Analyzer for encoders HENQ 1100 B