

Overview

- 20 ... 1000 mm
- push-pull
- qTeach, line-Teach, IO-Link
- connector M12 5 pin
- -25 ... 65 °C
- IP 67



Picture similar



Technical data

General data

Scanning range Sd	20 ... 1000 mm
Scanning range far limit Sde	20 ... 1000 mm
Version	IO-Link
Hysteresis typ.	4 % Sde
Repeat accuracy	< 0,5 mm
Temperature drift	< 2 % Sde
Power-up drift	Compensated after 15 min.
Response time ton	< 40 ms
Release time toff	< 40 ms
Sonic frequency	200 kHz
Adjustment	qTeach, line-Teach, IO-Link
Light indicator	LED yellow
Power on indication	LED green
Alignment measuring axis	< 2°

Electrical data

Voltage supply range +Vs	12 ... 30 VDC
Current consumption typ.	35 mA
Output circuit	Push-pull
Output current	< 100 mA
Voltage drop Vd	< 3,5 VDC
Residual ripple	< 10 % Vs
Short circuit protection	Yes
Reverse polarity protection	Yes

Communication interface

Interface	IO-Link V1.1
Baud rate	38,4 kBaud (COM 2)
Cycle time	≥ 12 ms
Process data length	48 Bit
Process data structure	Bit 0 = SSC1 (distance) Bit 1 = SSC2 (distance) Bit 2 = quality Bit 3 = alarm Bit 5 = SSC4 (counter) Bit 8-15 = scale factor Bit 16-47 = 32 Bit measurement
IO-Link port type	Class A
Additional data	Distance Excess gain Operating cycles Operating hours Boot cycles Operating voltage Device temperature Histograms

Technical data

Communication interface

Adjustable parameters	Time filters
	LED status indicators
	Output logic
	Output circuit
	Counter
	Beam forming
	Function of pin 5
	Deactivate the sensor element
Find Me function	

Mechanical data

Type	Rectangular
Housing material	Plastic (ASA, PMMA)

Mechanical data

Coating active face	PEEK
Width / diameter	18 mm
Height / length	45 mm
Depth	32 mm
Connection types	Connector M12 5 pin

Ambient conditions

Operating temperature	-25 ... +65 °C
Storage temperature	-40 ... +75 °C
Protection class	IP 67

Dimension drawing

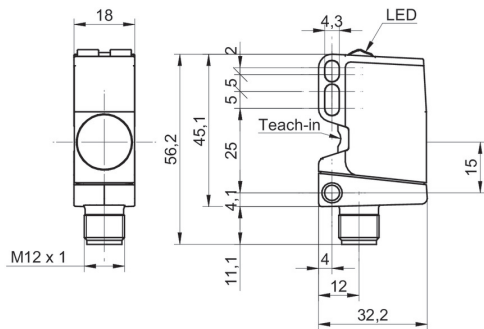

Typical sonic cone profile

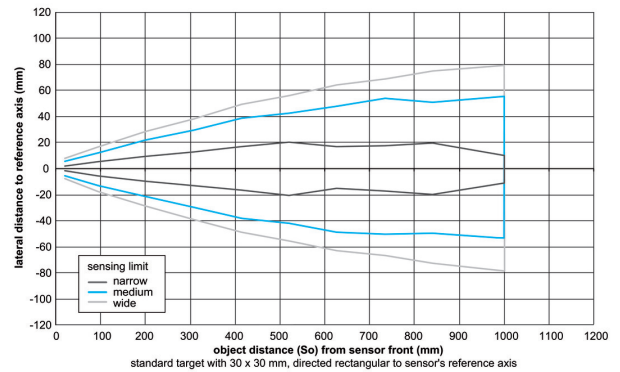

Connection diagram

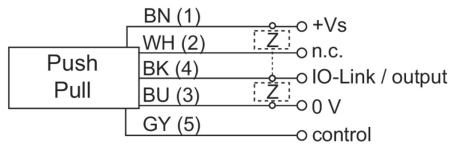

Pin assignment

