

# V CXG.2-127M.I

Gigabit Ethernet, 12.2 Megapixel, Monochrome

Article number: 11708120

## Overview

- 4096 x 2992 px
- Sony IMX545
- 1/1.1" CMOS
- 10 fps
- Gigabit Ethernet



Picture similar



GEN*i*CAM



## Technical data

### Sensor information

Sensor	Sony IMX545 Gen4
Mono/Color	Mono
Sensor type	1/1.1" CMOS
Shutter type	Global shutter
Resolution	4096 × 2992 px
Pixel size	2.74 × 2.74 μm
Exposure time	0.001 ... 60000 ms

### Data quality (EMVA 1288 typical)

Dark noise	2.33 e-
Saturation capacity	9087 e-
Dynamic range	69.7 dB
Signal-to-noise ratio	39.6 dB
Quantum efficiency	65.1 % @ 535 nm

### Acquisition formats

Image formats, interface frame rate max.	Full Frame, 4096 × 2992 px, max. 10 fps Binning 2×2, 2048 × 1496 px, max. 40 fps Binning 2×1, 2048 × 2992 px, max. 11 fps Binning 1×2, 4096 × 1496 px, max. 11 fps
Image formats, acquisition frame rate max. (Burst Mode)	Full Frame, 4096 × 2992 px, max. 11 fps
Pixel formats	Mono8 Mono10 Mono12 Mono12 Packed

### Image preprocessing

Analog controls	Gain (0 ... 48 dB) Offset (0 ... 255 LSB 12 Bit)
Color models	Mono
<b>Camera features</b>	
Basic Functions	Exposure Gain Trigger / Exposure Active (Flash) Binning 2x2 Partial Scan Offset Free Running Mode (Live Image)
Auto Functions	Exposure Auto Gain Auto
Image Pre-processing	Image Flipping (X/Y) LUT / Gamma
Acquisition / Interface	Burst Mode Adjustable Framerate Device Link Throughput Limit Internal Image Buffer
Synchronization	free running trigger
Trigger sources	Hardware Software ActionCommand
Trigger delay	0 ... 2 sec, tracking and buffering of up to 256 trigger signals

The product features and technical data specified do not express or imply any warranty. Technical modifications subject to change.

# VCXG.2-127M.I

Gigabit Ethernet, 12.2 Megapixel, Monochrome

Article number: 11708120

## Technical data

### Camera features

Process Synchronization	<ul style="list-style-type: none"> <li>Events</li> <li>Timer</li> <li>Trigger Delay</li> <li>Debouncer</li> <li>Counter</li> <li>Sequencer</li> <li>Trigger via Action CMD (GigE)</li> <li>Additional Output Modes (e.g. Trigger Ready)</li> <li>PWM (PWM Duration / PWM Duty Cycle)</li> <li>4 power outputs with up to 120 W (max. 48 V / 2.5 A)</li> <li>Selectable Output format (e.g. Tri State, Push Pull)</li> <li>Chunk data inside transferred image</li> <li>Encoder support via Counter End trigger source</li> </ul>
Additional Functions	<ul style="list-style-type: none"> <li>User Set</li> <li>Integrated temperature sensor</li> <li>Readable additional information (e.g. sensor information)</li> </ul>
Calibration data	<ul style="list-style-type: none"> <li>Camera calibration data (user defined storage for intrinsic / extrinsic camera parameters, and geometry distortion values)</li> <li>Customer data storage (128 bytes user defined)</li> </ul>
Internal image buffer	<ul style="list-style-type: none"> <li>141 MB</li> <li>4 image (Trigger Mode)</li> <li>1 image (Free Running Mode)</li> </ul>

### Interfaces and connectors

Data interface	Gigabit Ethernet, Transfer rate 1000 Mb/s, Fast Ethernet, Transfer rate 100 Mb/s, Connector: M12 / 8 pol x-coded, screwable type
Process interface	M12 / 12 pins a-coded (SACC-CI-M12MS-12CON-L180)
Power supply	via M12/12 pins a-coded or Power over Ethernet (PoE)

### Mechanical data

Lens mount	C-mount
------------	---------

### Mechanical data

Width	40 mm
Height	40 mm
Depth	50.8 mm
Weight	≤ 137 g
Material	aluminum, hard-anodized

### Electrical data

Voltage supply range +Vs	12 ... 24 V DC (external power supply) 36 ... 57 V DC (Power over Ethernet)
Power consumption	Approx. 3.1 W @ 12 VDC and 10 fps Approx. 3.8 W @ 48 VDC (PoE) and 10 fps

### Non-volatile memory

Flash memory size	128 kB
-------------------	--------

### Environmental conditions

Operating temperature	0 ... +65 ° @ T = measurement point
Storage temperature	-20 ... +70 °C
Humidity	10 ... 90 % (non-condensing)
Protection class	<ul style="list-style-type: none"> <li>IP 40 (with mounted lens and cable)</li> <li>IP 54 (with mounted lens and cable)</li> <li>IP 65 (with mounted tube and cable)</li> <li>IP 67 (with mounted tube and cable)</li> <li>IP 69K (with stainless steel housing accessory)</li> </ul>

### Digital I/Os

Lines	<ul style="list-style-type: none"> <li>4 input lines</li> <li>4 power output lines with pulse width modulation (PWM) (max. 48 V / max. 2.5 A)</li> </ul>
Output line sources	<ul style="list-style-type: none"> <li>Off</li> <li>Line 0-3</li> <li>Exposure Active</li> <li>Timer1Active</li> <li>Readout Active</li> <li>UserOutput 1-4</li> <li>TriggerReady</li> </ul>

### Conformity

Conformity	<ul style="list-style-type: none"> <li>CE</li> <li>RoHS</li> </ul>
------------	--

# VCXG.2-127M.I

Gigabit Ethernet, 12.2 Megapixel, Monochrome

Article number: 11708120

## Dimension drawing

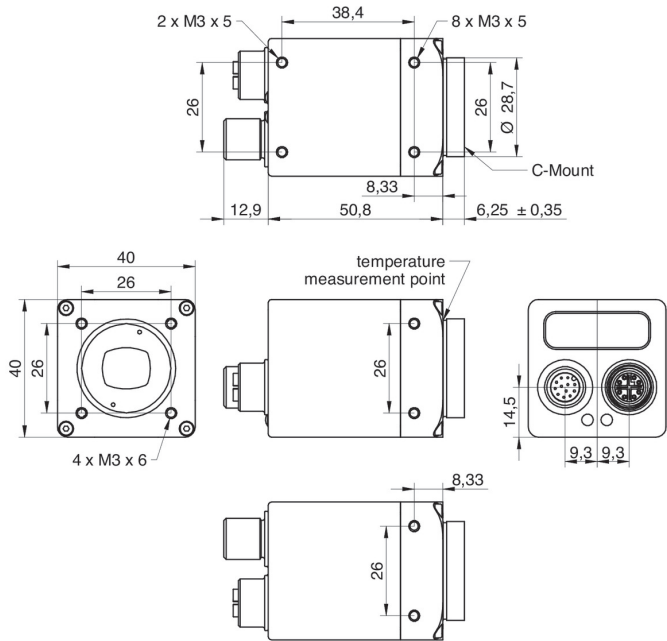

## Principle

Optional accessories for protection class IP 65/67:

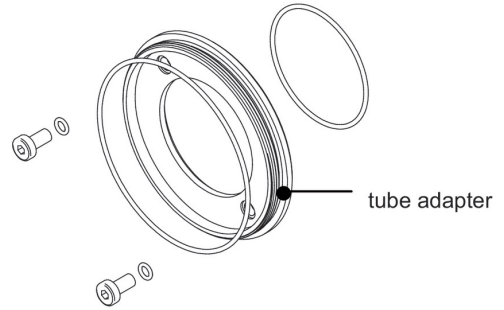

tube adapter

- hard-anodized, incl. sealing and screws  
 Ø 49,5 mm (VCXG.I 11185373)  
 Ø 65 mm (VCXG.I 11185377)  
 Ø 95 mm (VCXG.I 11704311)  
 Ø 65 mm (VLXT 11193125)  
 Ø 95 mm (VLXT.EF 11704315)

## Principle

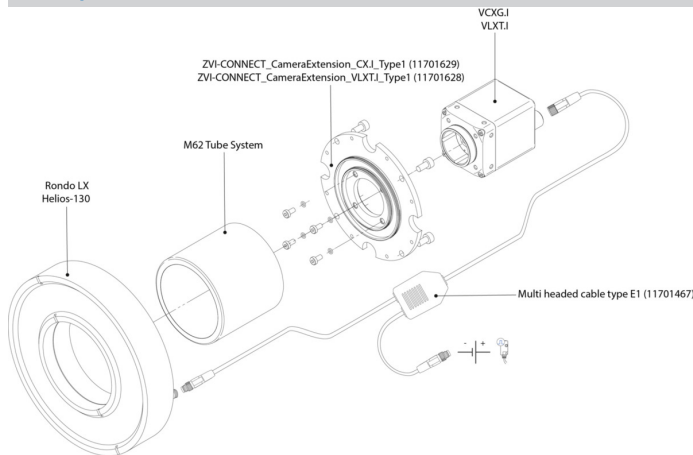

tube

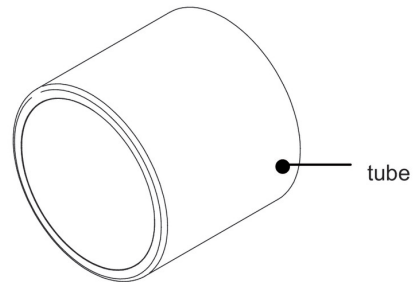

- hard-anodized, cover glass PMMA  
 Ø 49,5 mm, Length 44 mm (11185370)  
 Ø 65 mm, Length 58 mm (11185374)  
 Ø 95 mm, length 70 mm (11704312)
- hard-anodized, tempered laminated safety glass  
 Ø 49,5 mm, Length 44 mm (11701124)  
 Ø 65 mm, Length 58 mm (11701125)

## Principle

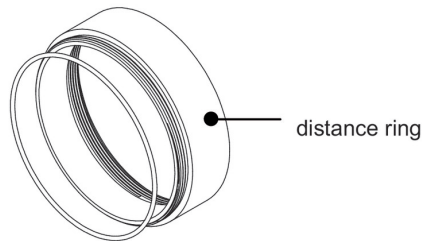

distance ring

- hard-anodized, incl. sealing
  - Ø 49,5 mm, Length 6 mm (11185372)
  - Ø 49,5 mm, Length 12 mm (11185371)
  - Ø 49,5 mm, Length 36 mm (11211571)
  
  - Ø 65 mm, Length 6 mm (11185376)
  - Ø 65 mm, Length 12 mm (11185375)
  - Ø 65 mm, Length 36 mm (111988906)
  
  - Ø 95 mm, length 6 mm (11704395)
  - Ø 95 mm, length 12 mm (11704397)
  - Ø 95 mm, length 36 mm (11704394)