

Edge sensors

OXE7.E25T-11111452

dimension drawing

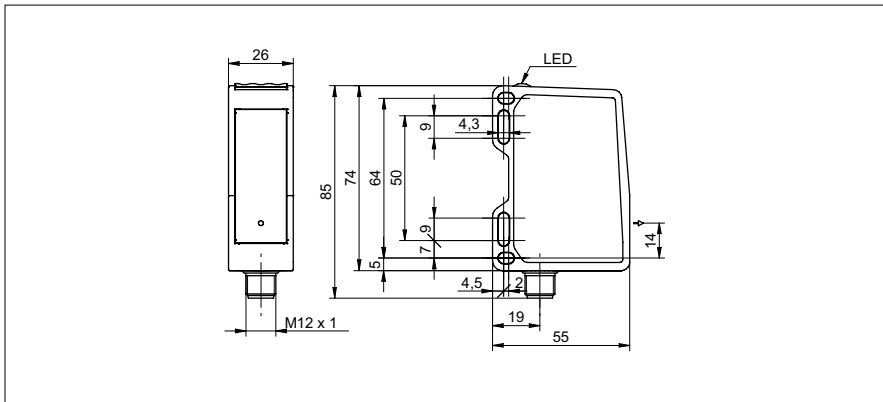

general data

type	measuring mode: edges, center, width, gap
version	PosCon OXE7
measuring range (width)	75 ... 125 mm
measuring range (distance)	150 ... 250 mm
measuring frequency	125 ... 500 Hz
resolution	30 ... 50 µm
repeat accuracy	± 10 µm
smallest detectable object width	1,5 mm
smallest detectable gap	2 mm
smallest detectable step	2 mm
linearity error	± 80 ... ± 120 µm
temperature drift	< 0,05 % measured value/K
power on indication	LED green
output indicator	LED yellow / LED red
light source	pulsed red laser diode
wave length	656 nm
laser class	1
optical peak power max.	3 mW
adjustment	Touch Display, RS485

electrical data

response time / release time	4 ... 16 ms
voltage supply range +Vs	15 ... 28 VDC
current consumption max. (no load)	150 mA
output circuit	analog and RS 485
output signal	4 ... 20 mA / 0 ... 10 VDC
switching output	push-pull
output function	Out 1 / Alarm
output current	< 100 mA
baud rate	115200, adjustable
reverse polarity protection	yes, Vs to GND
short circuit protection	yes

photo



connection diagram

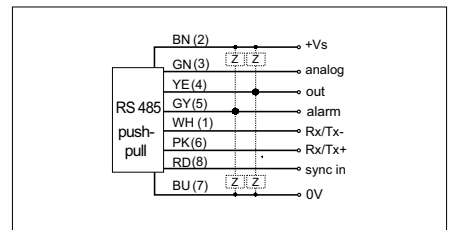

alignment of the laser line

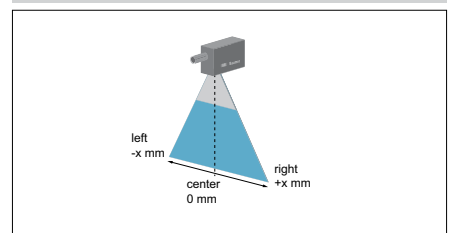

**Edge sensors**
**OXE7.E25T-11111452**
**mechanical data**

width / diameter	26 mm
height / length	74 mm
depth	55 mm
type	rectangular, front view
housing material	aluminum
front (optics)	glass
connection types	connector M12 8 pin
weight	130 g

**ambient conditions**

ambient light immunity	< 25 kLux
operating temperature	-20 ... +50 °C
protection class	IP 67
storage temperature	-25 ... +75 °C
vibration (sinusoidal)	IEC 60068-2-6:2008 1.5 mm p-p at f = 10 - 57 Hz, 10 cycles per axis 10 g at f = 58 - 2000 Hz, 10 cycles per axis
shock (semi-sinusoidal)	IEC 60068-2-27:2009 50 g / 11 ms resp. 100 g / 6 ms, 10 jolts per axis and direction 100 g / 2 ms, 5000 jolts per axis and direction

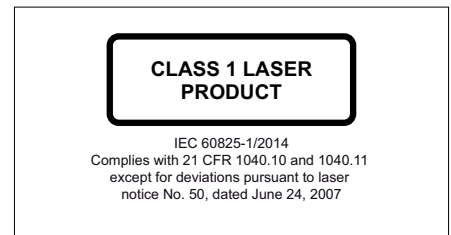
**laser warning**

- Conditions for the following characteristics:
- measuring frequency 1) 2)
- resolution 1) 3)
- repeat accuracy 1) 3)
- linearity error 1) 4)
- response time / release time 1) 2) 3)
- 1) Measurement with Baumer standardized measuring equipment and targets. Measuring on 90% reflectivity (white)
- 2) Depending on the size of the measuring field and OBJECT light/dark mode
- 3) Without filtering / no averaging
- 4) Measured symmetrically around the reference point with 50% of the measuring field