

VLG-40C.2.I

Technical Data

 Art. No.
11115309

Digital Color Matrix Camera, IP65/67, Gigabit Ethernet

Sensor Information

Model Name	CMOSIS CMV-4000 V3
Type	1" progressive scan CMOS
Shutter	Global
Native Resolution	2040 x 2044 pixels
Scan Area	11.26 mm x 11.26 mm
Pixel Size	5.5 μm x 5.5 μm

Data Quality

@ 20 °C, gain = 1, exposure time = 32 msec

Readout Noise (σ)	0.3 LSB @ 8 bit, 4.5 LSB @ 12 bit (typical)
Dynamic Range	60 dB (typical)

Acquisition Formats

Image Formats	Format	Resolution	Frame Rate	t_{readout}
	Full Frame	2040 x 2044	29 fps	34.5 msec
Pixel Formats	Mono8, BayerRG8, BayerRG12, RGB8Packed, BGR8Packed, YUV411Packed, YUV422Packed, YUV444Packed			
Partial Scan	True Partial Scan, Region of Interest (ROI) arbitrary			

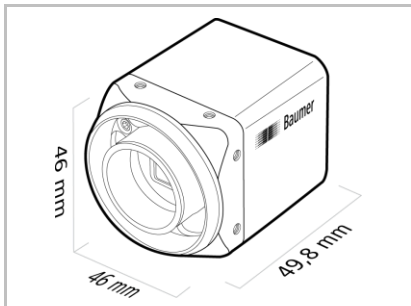

Sensor Graph: Relative Response

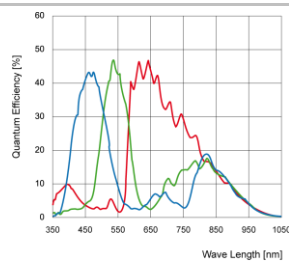
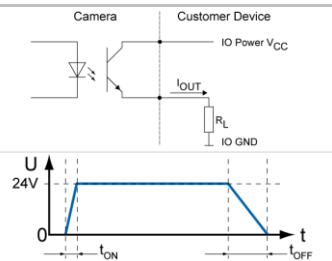

Image Pre-Processing

Analog Controls	Exposure Time (20 μsec ... 1 sec Step Size 1 μsec) Gain (0 ... 18 dB), Offset (0 ... 255 LSB 12 bit),
Gamma Correction	Gamma (0.1 ... 2 available if LUT is enabled)
LUT	Luminance (12 bit)
Color Models	RGB, YUV, Mono
Color Tolerance	0.2% (typical)
Color Processing	Integrated color processor for high quality color calculation
Color Adjustment	White Balance (manual & one push)
Binning Horizontal	1 or 2 (true color binning)
Binning Vertical	1 or 2 (true color binning)
Image Flipping	Horizontal, vertical
Defect Pixel Correction	via Defect Pixel List with up to 511 Pixel Coordinates

Digital Output: High Active



Digital Output: Low Active

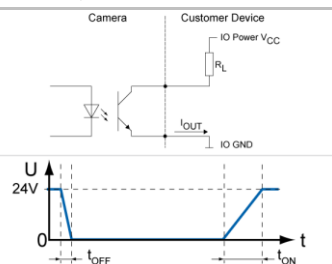

Process Synchronization

Modes	Free Running, Trigger
Free Running	Continuous or Adjustable Acquisition Frame Rate (0 ... 9.427 Hz)
Trigger Sources	Hardware, Software, ActionCommand, All or Off
Trigger Delay	0 ... 2 sec, Tracking and buffering of up to 512 triggers
Sequencer Characteristics	up to 128 sets of parameters, up to 65536 loop passes, up to 65536 repetitions of sets of parameters, up to 65536 images per trigger event
Sequencer Parameters	Exposure Time, Gain Factor, Output Line, ROI Offset x, ROI offset y
External Flash Sync	via Exposure Active $t_{\text{delay flash}} \leq 3 \mu\text{sec}$, $t_{\text{duration}} = t_{\text{exposure}} + 18 \mu\text{sec}$

Digital I/Os

Lines	Input: Line 0, Output: Line1, Line 2, Line 3
Circuit Times	Output: $t_{\text{ON}} = \text{typ. } 3 \mu\text{sec}$ $t_{\text{OFF}} = \text{typ. } 40 \mu\text{sec}$
Output Sources	Off, ExposureActive, Line 0, Timer1 ... 3, ReadoutActive, User0 ... 2, TriggerReady, TriggerOverlapped, TriggerSkipped, Sequencer Output 0 ... 2
Line Debouncer	Low and high signal separately selectable Debouncing Time 0 ... 5 msec, Step Size: 1 μsec

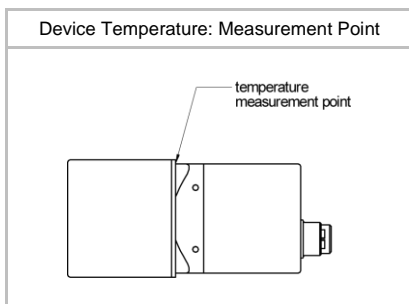
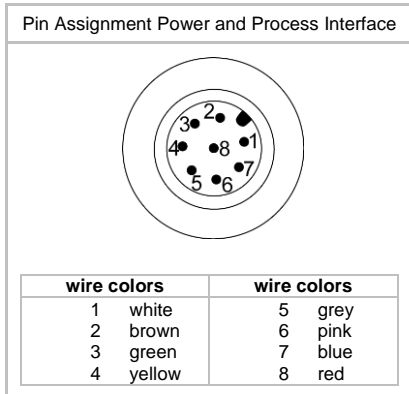
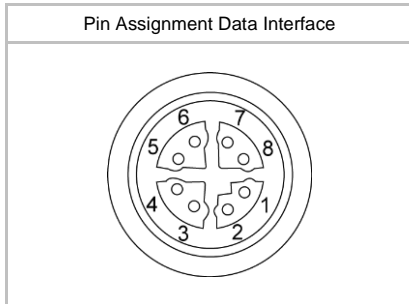
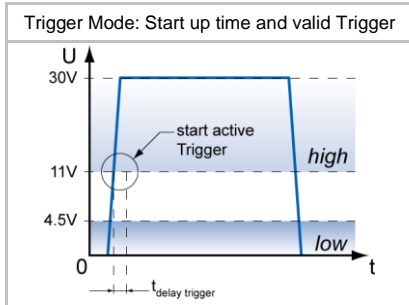
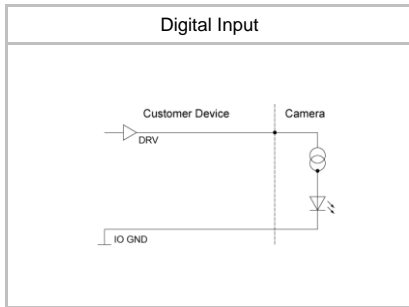

Interfaces and Connectors

Data Interface	Gigabit Ethernet	Transfer Rate	1000 Mbits/sec
	Fast Ethernet	Transfer Rate	100 Mbits/sec
	Connector:	SACC-CI-M12FS-8CON-L180-10G	
	Pin Assignment:	1 – MX1+	5 – MX4+
		2 – MX1-	6 – MX4-
		3 – MX2+	7 – MX3-
		4 – MX2-	8 – MX3+
Process- / Power Interface	Connector:	SACC-CI-M12MS-8CON-SH TOR 32	
	Assignment:	1 – OUT 3	5 – IO Power VCC
		2 – Power VCC+	6 – OUT 1
		3 – IN1	7 – Power GND
		4 – IO GND	8 – OUT 2

Mechanical Data

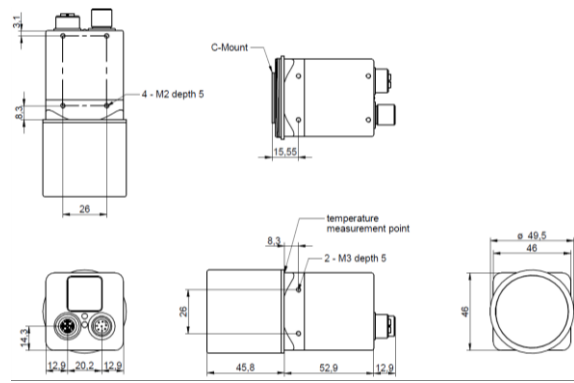
Housing	Aluminum, IP65/67
Dimensions	
Weight	185 g (220g incl. Tube)

Optical Data

Lens Mount	C-Mount
Optical Filter	IR-Cut Filter

Electrical Data

Power Supply (ext.)	VCC:	12 ... 24 V DC ± 20%
	I:	149 ... 286 mA
Power over Ethernet	Class 0 device	
	VCC:	36 ... 57 V DC
	I:	80 mA @ 48 VDC
Power Consumption	approx.	3.6 W @ 12 VDC and 29 fps
	approx.	3.8 W @ 48 VDC (PoE) and 29 fps
Digital Input	$U_{IN(low)}$:	0.0 ... 4.5 VDC
	$U_{IN(high)}$:	11.0 ... 30.0 VDC
	I_{IN} :	6.0 ... 10 mA
	min. Impulse Length:	2.0 µsec
	Trigger Delay out of t _{readout} :	1.0 µsec
	max. Trigger Delay during t _{readout} :	14.0 µsec
Digital Output	U_{EXT} :	5 ... 30 V DC
	I_{OUT} :	max. 50 mA

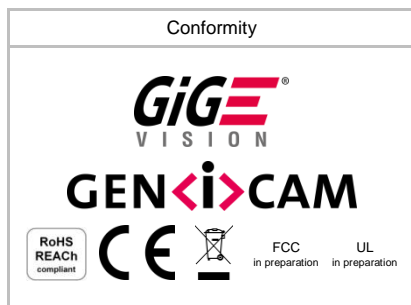
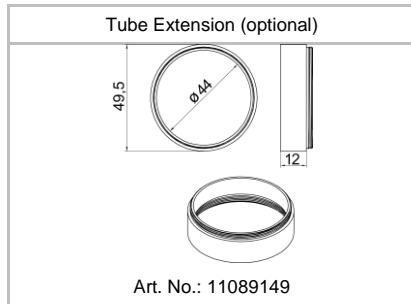
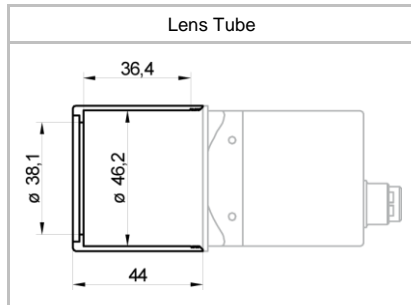
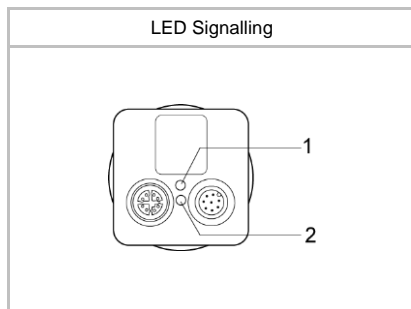

LED Signalling

LED 1 (top)	Green	Link active
	Green flash	Receiving
LED 2 (bottom)	Yellow	Transmitting

Environmental Data

Storage Temperature	-10 °C bis +70 °C	
Operating Temperature	+5°C ... +50°C	
Device Temperature	T _{max} = 50 °C @ Measurement Point	
Humidity	10 % ... 90 % non-condensing	
Conformity	In preparation	

Network Interface Data

Network Interface	Gigabit Ethernet	1000BASE-T	1000 Mbits/sec
	Fast Ethernet	100 BASE-T	100 Mbits/sec
Ethernet IP Configuration	Persistent IP, DHCP, LLA		
Packet Size	576 ... 16 KByte, Jumbo Frames supported		

GigE Vision® Features

Events Transmission via Asynchronous Message Channel	PrimaryApplicationStitch, GigEVisionError, GigEVisionHeartbeatTimeOut, EventLost, EventDiscarded, Line0RisingEdge, Line0FallingEdge, Line1RisingEdge, Line1FallingEdge, Line2RisingEdge, Line2FallingEdge, Line3RisingEdge, Line3FallingEdge, ExposureStart, ExposureEnd, FrameStart, FrameEnd, TriggerReady, TriggerOverlapped, TriggerSkipped		
Frame Counter	up to 2 ³²		
Payload Size	4 ... 12.534.080 Byte		
Transmission Delay	0 .. 2 ³² -1 Ticks (1 Tick = 32 nsec)		
Timestamp	64 bit		
Packet Delay	0 .. 2 ³² -1 Ticks		
Packet Resend	Resend Buffer:	120 MB (10 Images)	

GenICam™ Features

Timer	Timer Selector: Timer 1 ... 3 TimerTriggerSource: Line0, SoftwareTrigger, CommandTrigger, ExposureStart, ExposureEnd, FrameStart, FrameEnd, TriggerSkipped, Off TimerDelay: 0 µsec ... 2 sec, Step Size: 1 µsec TimerDuration: 10 µsec ... 2 sec, Step Size: 1 µsec		
User Sets	Factory Settings:	UserSet0 (read only)	
	Freely Programmable:	UserSet1, UserSet2, UserSet3	
	Parameters:	any user definable Parameter	
Acquisition Abort	Delay up to 69 msec		

Vendor Specific Features

FPN Correction	
HDR	

Factory Settings after Start-Up

Operation Mode	Free Running
Analog Controls	Exposure Time: 4 msec, Gain: 0 dB, Offset: 0
Pixel Format	BayerRG8
Partial Scan	Off
Acquisition Frame Rate	Off
Timer	Off
Transmission Delay	Off
Defect Pixel Correction	On
Digital Input	Line0, invert = false, trigger source = All
Digital Output	Line1, invert = false, line source = Off