

# O300.SP-11140097

SmartReflect Lichtschranken

SmartReflect Light barriers

Barrières SmartReflect



11140097



## Baumer

Baumer Electric AG · CH-8501 Frauenfeld  
Phone +41 (0)52 728 1122 · Fax +41 (0)52 728 1144

**Canada**  
Baumer Inc.  
CA-Burlington, ON L7M 4B9  
Phone +1 (1)905 335-8444

**Italy**  
Baumer Italia S.r.l.  
IT-20090 Assago, MI  
Phone +39 (0)2 45 70 60 65

**China**  
Baumer (China) Co., Ltd.  
CN-201612 Shanghai  
Phone +86 (0)21 6768 7095

**Singapore**  
Baumer (Singapore) Pte. Ltd.  
SG-339412 Singapore  
Phone +65 6396 4131

**Denmark**  
Baumer A/S  
DK-8210 Aarhus V  
Phone +45 (0)8931 7611

**Sweden**  
Baumer A/S  
SE-56133 Huskvarna  
Phone +46 (0)36 13 94 30

**France**  
Baumer SAS  
FR-74250 Fillinges  
Phone +33 (0)450 392 466

**Switzerland**  
Baumer Electric AG  
CH-8501 Frauenfeld  
Phone +41 (0)52 728 1313

**Germany**  
Baumer GmbH  
DE-61169 Friedberg  
Phone +49 (0)6031 60 07 0

**United Kingdom**  
Baumer Ltd.  
GB-Watchfield, Swindon, SN6 8TZ  
Phone +44 (0)1793 783 839

**India**  
Baumer India Private Limited  
IN-411038 Pune  
Phone +91 20 2528 6833/34

**USA**  
Baumer Ltd.  
US-Southington, CT 06489  
Phone +1 (1)860 621-2121

www.baumer.com/worldwide

### Abmessungen Dimensions Dimensions

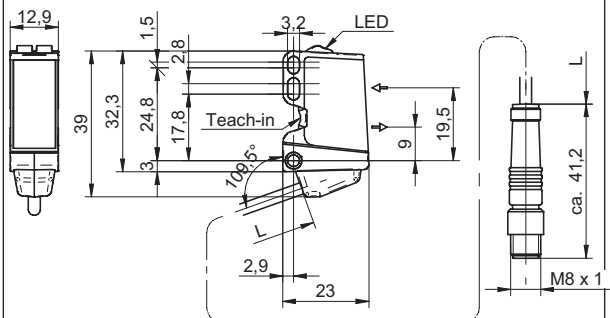

- Alle Masse in mm
  - All dimensions in mm
  - Toutes les dimensions en mm
- Kabellänge L = 200 mm  
cable length L = 200 mm  
Longueur du câble L = 200 mm

### Elektrischer Anschluss Connection diagram Schéma de raccordement

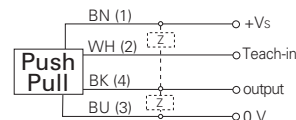

BN = Braun/brown/brun  
WH = Weiss/white/blanc  
BK = Schwarz/black/noir  
BU = Blau/blue/bleu

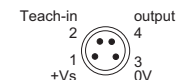

<sup>1)</sup> Class 2, UL 1310, see FAQ

- Vor dem Anschliessen des Sensors die Anlage spannungsfrei schalten.
- Disconnect power before connecting the sensor.
- Mettre l'installation hors tension avant le raccordement du détecteur.

### Technische Daten

### Technical data

### Données techniques

Hintergrundposition Sde	30 ... 300 mm	background position Sde	30 ... 300 mm	Position de l'arrière plan Sde	30 ... 300 mm
Erfassungsbereich Sa	90% ... 85% Sde	scanning range Sa	90% ... 85% Sde	Plage de détection Sa	90% ... 85% Sde
Ausrichtung optische Achse	< 2°	alignment optical axis	< 2°	Axe d'alignement optique	< 2°
Betriebsspannungsreich +Vs <sup>1)</sup>	10 ... 30 VDC	voltage supply range +Vs <sup>1)</sup>	10 ... 30 VDC	Plage de tension +Vs <sup>1)</sup>	10 ... 30 VDC
Stromaufnahme max. (ohne Last)	45 mA	current consumption max. (no load)	45 mA	Consommation max. (sans charge)	45 mA
Stromaufnahme mittel	30 mA	current consumption typ.	30 mA	Courant absorbé moyen	30 mA
Spannungsabfall Vd	< 3 VDC	voltage drop Vd	< 3 VDC	Tension résiduelle Vd	< 3 VDC
Ansprech- / Abfallzeit	< 0,49 ms	response time / release time	< 0,49 ms	Temps d'activation / désactivation	< 0,49 ms
Ausgangsschaltung	Gegentakt	output circuit	push-pull	Circuit de sortie	push-pull
Schaltfunktion	Hell- / Dunkel-schaltung	output function	light / dark operate	Fonction de commutation	claire/sombre
kurzschlussfest	ja	short circuit protection	yes	Protégé contre courts-circuits	oui
verpolungsfest	ja	reverse polarity protection	yes	Protégé contre inversion polarité	oui
Arbeitstemperatur	-25 ... +60 °C	operating temperature	-25 ... +60 °C	Température de fonctionnement	-25 ... +60 °C
Schutzart	IP 67	protection class	IP 67	Classe de protection	IP 67

Technische Änderungen vorbehalten Technical specifications subject to change Sous réserve de modifications techniques

## qTeach Status

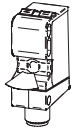

ready

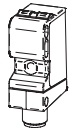

OFF

### Allgemeine Hinweise

- qTeach verriegelt 5 min nach dem Einschalten.
- Im Teachmodus wechselt der Ausgang auf 0 V.
- Im Normalbetrieb muss die Teachleitung auf LOW gelegt werden.
- Für externe Teach-in, Teachleitung entsprechend mit Vs+ verbinden.

### General information

- qTeach locks 5 min after switching on.
- In teach mode the output changes to 0 V.
- In normal mode the teach wire is set to LOW.
- For external teach-in, connect teach wire correspondingly to Vs+.

### Remarques générales

- qTeach se verrouille 5 min après l'enclenchement.
- En mode Teach, la sortie passe à 0 V.
- En fonctionnement normal, la connexion Teach doit être placée sur LOW.
- Pour le Teach-in externe, raccorder en conséquence la connexion Teach à Vs+.

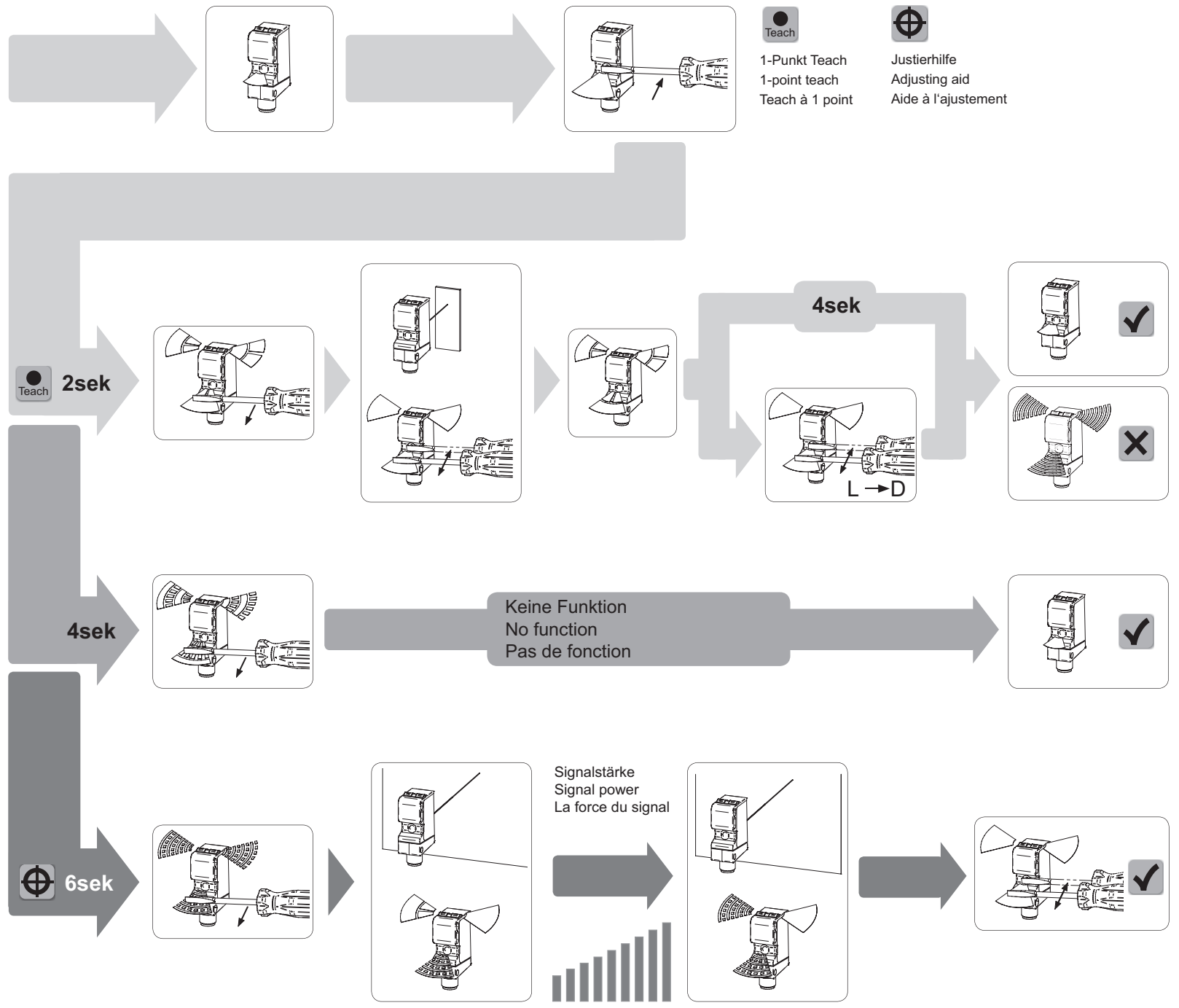

# O300.SP-11140097

## Blinkmodi Flashing modes Modes de clignotement

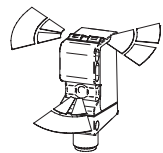

Blinken 1 Hz  
Flashing 1 Hz  
Clignotement 1 Hz

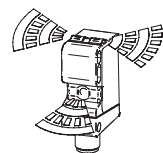

Blinken 2 Hz  
Flashing 2 Hz  
Clignotement 2 Hz



Blinken 4 Hz  
Flashing 4 Hz  
Clignotement 4 Hz

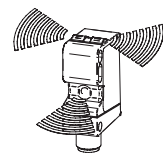

Blinken 8 Hz  
Flashing 8 Hz  
Clignotement 8 Hz

## Farben LED Colors LED Couleurs LED

gelb  
yellow  
jaune

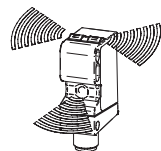

grün  
green  
vert

blau  
blue  
bleu

## qTeach Rückmeldung qTeach Feedback Retour qTeach

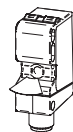

bereit  
ready  
prêt

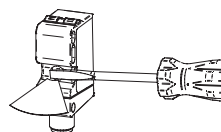

Werkzeug erkannt  
Tool detected  
Outil reconnu

## LED Anzeigen LED indication Indication LED

Grün: Betriebsanzeige, Kurzschluss  
Gelb: Lichtempfang, Justierhilfe, Teach Rückmeldung  
Blau: qTeach Rückmeldung

## Zubehör Accessories Accessoires

Montagewinkel  
Mounting bracket  
Support de montage  
Art. No: 11102423

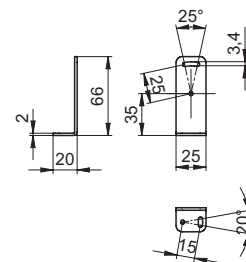

Sensofix O300  
Sensofix O300  
Sensofix O300  
Art. No: 11104963

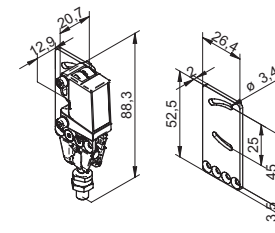

## Montage Mounting Montage

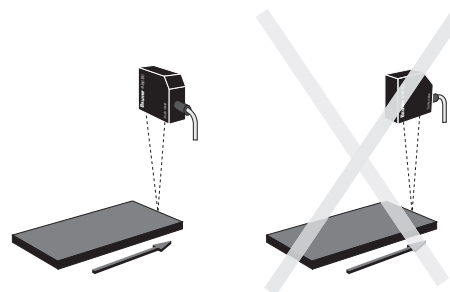

Green: Operating indication, short circuit  
Yellow: Light reception, adjusting aid, Teach feedback  
Blue: qTeach feedback

Vert: Signalisation de service, court-circuit  
Jaune: Réception de lumière, aide à l'ajustement, retour teach  
Bleu: Retour qTeach